

# Types 168, 168H, and 68-2 Three-Way, Snap-Acting Switching Valves

## Introduction

The Types 168 and 168H three-way, snap-acting switching valves provide fast, positive switching of pneumatic pressures in response to a predetermined change in a pneumatic input signal. These switches can be used to open and close pneumatically operated control valves, to load or exhaust pneumatic systems, or to operate a variety of pneumatic equipment.

Units are available for handling body pressures up to 150 psig (10,3 bar) with diaphragm pressures from 2 to 150 psi (0,14 to 10,3 bar). Maximum and minimum diaphragm pressure changes between switching points are shown in Table 1. The diaphragm pressures at which switching occurs are determined by the locations of the adjusting nuts. Types 168 and 168H switching valves are also available with a manual reset lever (see Figure 4).

The Type 68-2, shown in Figures 1 and 3, is a three-way, snap-acting switching valve that forms the valve body portion of the Types 168 and 168H switching valves. A manual reset switch, see Figure 4, may be adapted to the Types 168 and 168H switching valves to provide for manual reset. An extension of the trip lever allows the Type 68-2 to be used as a manual switching valve.

## Features

- **Fast, Positive Switching Action**—Trip lever motion increases spring load on the seat until the lever and spring mechanism passes dead center; then valve spring force “snaps” the rocker to its alternate position. Soft seat construction and fast switching action minimize leakage and throttling between seat rings.
- **Full Adjustability**—High and low tripping pressures can be adjusted throughout diaphragm pressure range.
- **Three-Way or On/Off Action**—With one connection (either B or C) plugged, unit can be used as on/off switch.
- **Suitable for Sour Gas Service**—No brass or bronze in trim parts.
- **Automatic or Manual Reset**—Unit may be set to automatically reset after tripping, keeping the pressure within the selected range. With both adjusting nuts in place, the unit trips at the upper (or lower) pressure limit and resets automatically when the lower (or upper) limit is reached. With one adjusting nut in place, the unit trips at the high (or low) pressure limit and remains in that position until it is reset. Reset may be achieved by removing the stem protector and tripping the switch or by tripping an optional reset lever (see Figure 4).

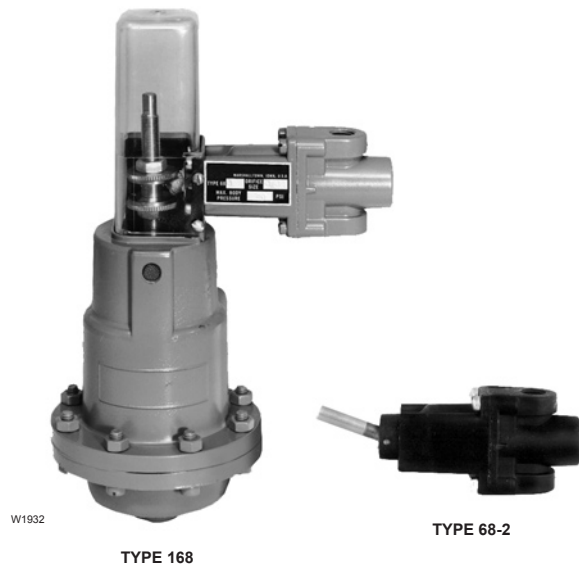

Figure 1. Type 168 Switching Valve and Type 68-2 Trip Lever

# Bulletin 71.7:168

## Specifications

### Available Configurations

- Type 68-2:** Manual three-way switching valve  
**Type 168:** Pneumatically operated three-way, snap-acting switching valve with diaphragm pressure range of 2 to 40 psig (0,14 to 2,8 bar) or 2 to 60 psig (0,14 to 4,1 bar)  
**Type 168H:** Pneumatically operated three-way, snap-acting switching valve with diaphragm pressure range of 35 to 100 psig (2,4 to 6,9 bar) or 50 to 150 psig (3,4 to 10,3 bar)

### Maximum Allowable Pressures<sup>(1)</sup>

See Table 1

### Temperature Capabilities<sup>(1, 2)</sup>

-10° to 150°F (-23° to 66°C)

### Flow Coefficients

**C<sub>g</sub>:** 7  
**Representative C<sub>1</sub>:** 35

### Port Diameter

3/32-inches (2,4 mm)

### Types 168 and 168H Options

- Mounting bracket suitable for use with 2-inch (51 mm) (nominal) pipestand
- Control valve yoke mounting parts
- Manual Reset switch

### Pressure Connections

1/4 NPT internal

### Mounting

**Type 68-2:** See Figure 3 for panel mounting  
**Types 168 and 168H:** Can be mounted using two tapped holes in the spring case, optional mounting bracket (see Figure 4), or optional control valve yoke mounting parts

### Approximate Weights

**Type 68-2:** 0.5 pound (0,2 kg)  
**Type 168:** 3 pounds (1 kg)  
**Type 168H:** 5 pounds (2 kg)

### Construction Materials

**Body and Cases:** Aluminum  
**Diaphragm:** Dacron® covered with Nitrile (NBR)  
**Seat Rings:** Stainless steel  
**Rocker Assembly:** Glass-filled nylon (PA) with polyurethane valve disks  
**Stem and Adjusting Nuts:** Stainless steel  
**Stem Bushing:** Steel and Polytetrafluoroethylene PTFE  
**O-Rings:** Nitrile (NBR)  
**Actuator Spring:** Steel  
**Valve Spring:** Stainless steel  
**Trip Lever:** Stainless steel  
**Stem Protector:** Plastic

1. The pressure/temperature limits in this bulletin or any applicable standard limitation should not be exceeded.

2. This term is defined in ISA Standard S51.1-1979.

Dacron® is a mark owned by E.I. du Pont de Nemours and Co.

**Table 1. Maximum Pressures and Spring Color Codes**

TYPE NUMBER	DIAPHRAGM PRESSURE CHANGE BETWEEN SWITCHING POINTS, PSIG (bar)		DIAPHRAGM PRESSURE RANGE, PSIG (bar)	DIAPHRAGM SPRING COLOR	MAXIMUM ALLOWABLE BODY PRESSURE, PSIG (bar)	BODY SPRING COLOR
	Minimum	Maximum				
68-2	----	----	----	----	150 (10,3)	Unpainted
168-1	10 (0,69)	58 (4,0)	2 to 60 (0,14 to 4,1)	Green	150 (10,3)	Unpainted
168-2	10 (0,69)	38 (2,6)	2 to 40 (0,14 to 2,8)	Yellow	150 (10,3)	Unpainted
168-3	10 (0,69)	58 (4,0)	2 to 60 (0,14 to 4,1)	Green	40 (2,8)	Yellow
168-4	7 (0,48)	38 (2,6)	2 to 40 (0,14 to 2,8)	Yellow	40 (2,8)	Yellow
168H-1	20 (1,38)	100 (6,9)	50 to 150 (3,4 to 10,3)	Green	150 (10,3)	Unpainted
168H-2	20 (1,38)	65 (4,5)	35 to 100 (2,4 to 6,9)	Yellow	150 (10,3)	Unpainted
168H-3	20 (1,38)	100 (6,9)	50 to 150 (3,4 to 10,3)	Green	40 (2,8)	Yellow
168H-4	16 (1,10)	65 (4,5)	35 to 100 (2,4 to 6,9)	Yellow	40 (2,8)	Yellow

## Principle of Operation

In operation, increasing diaphragm pressure from a controller or other source moves the stem and upper adjusting nut toward the trip lever (see Figure 2). When the diaphragm pressure reaches the predetermined upper switching point, the upper adjusting nut pivots the trip lever to move the rocker assembly to its alternate position, closing port C and opening port B.

When decreasing diaphragm pressure reaches the lower tripping pressure, the lower adjusting nut returns the rocker to its original position.

## Installation

Type 68-2 switching valves may be installed in any position.

Types 168 and 168H switching valves should be positioned so that moisture cannot enter either the vent or the small hole in the end of the stem protector. Pipe the common pressure line to connection A (the connection located in the end of the body portion).

Dimensions are shown in Figures 3 and 4.

## Ordering Information

### Type 68-2

When ordering, specify:

1. Type number
2. Maximum inlet pressure to body

### Types 168 and 168H

When ordering, specify:

1. Type number
2. Diaphragm pressure range
3. Upper and lower tripping pressures
4. Maximum inlet pressure to body
5. Optional mounting bracket, manual reset switch, or control valve yoke mounting parts if desired. If control valve yoke mounting parts are ordered, specify actuator type and size.

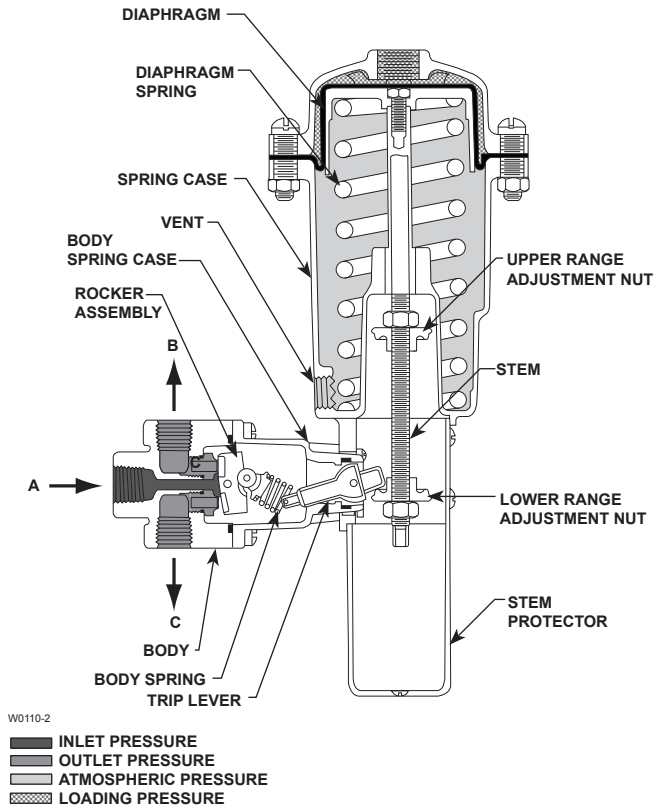

Figure 2. Type 168 Operational Schematic

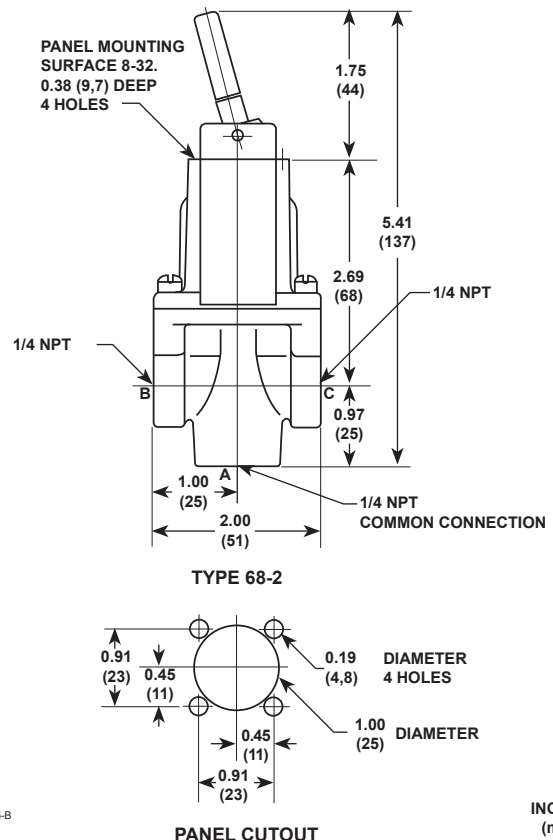
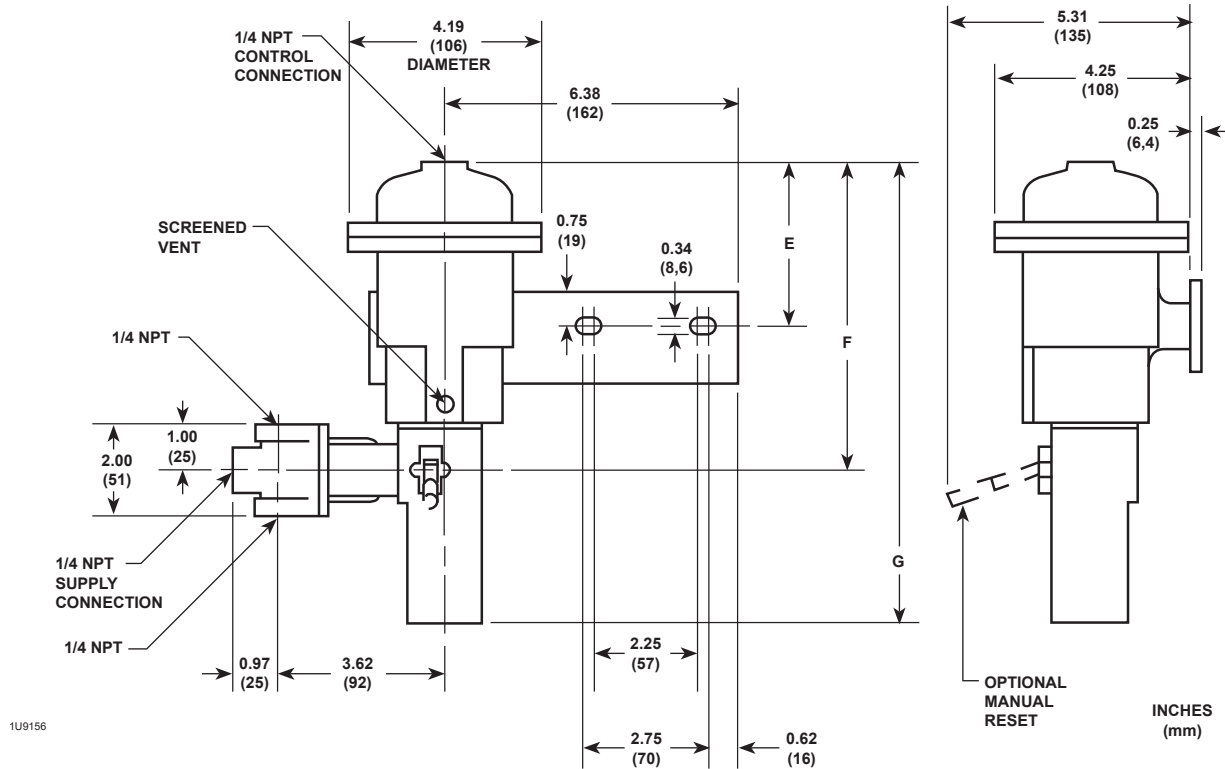

Figure 3. Type 68-2 Switching Valve Dimensions

# Bulletin 71.7:168



TYPE NUMBER	DIMENSIONS, INCHES (mm)		
	E	F	G
168	3.56 (90)	6.69 (170)	10.0 (254)
168H	5.00 (127)	8.12 (206)	11.44 (291)

Figure 4. Types 168 and 168H Switching Valves with Manual Reset Switch Dimensions

## Industrial Regulators

### Emerson Process Management Regulator Technologies, Inc.

USA - Headquarters  
McKinney, Texas 75069-1872 USA  
Tel: 1-800-558-5853  
Outside U.S. 1-972-548-3574

Asia-Pacific  
Shanghai, China 201206  
Tel: +86 21 2892 9000

Europe  
Bologna, Italy 40013  
Tel: +39 051 4190611

Middle East and Africa  
Dubai, United Arab Emirates  
Tel: +971 4811 8100

## Natural Gas Technologies

### Emerson Process Management Regulator Technologies, Inc.

USA - Headquarters  
McKinney, Texas 75069-1872 USA  
Tel: 1-800-558-5853  
Outside U.S. 1-972-548-3574

Asia-Pacific  
Singapore, Singapore 128461  
Tel: +65 6777 8211

Europe  
Bologna, Italy 40013  
Tel: +39 051 4190611  
Gallardon, France 28320  
Tel: +33 (0)2 37 33 47 00

## TESCOM

### Emerson Process Management Tescom Corporation

USA - Headquarters  
Elk River, Minnesota 55330-2445 USA  
Tel: 1-763-241-3238

Europe  
Selmsdorf, Germany 23923  
Tel: +49 (0) 38823 31 0

For further information visit [www.emersonprocess.com/regulators](http://www.emersonprocess.com/regulators)

The Emerson logo is a trademark and service mark of Emerson Electric Co. All other marks are the property of their prospective owners. Fisher is a mark owned by Fisher Controls, Inc., a business of Emerson Process Management.

The contents of this publication are presented for informational purposes only, and while every effort has been made to ensure their accuracy, they are not to be construed as warranties or guarantees, express or implied, regarding the products or services described herein or their use or applicability. We reserve the right to modify or improve the designs or specifications of such products at any time without notice.

Emerson Process Management does not assume responsibility for the selection, use or maintenance of any product. Responsibility for proper selection, use and maintenance of any Emerson Process Management product remains solely with the purchaser.