

## Askalon Fail Safe Electric Lock-in-last position unit

Pneumatic actuators can have three fail positions if air supply fails.

Positions are fail close, fail stay or fail open.

For spring return diaphragm actuators fail close and open are spring forced.

Fail lock is performed by switch valve Fisher 167DA.

Double action piston actuators have fail positions using Fisher 377 Trip Valve relay. Fail close and open must have air bottle.

Askalon has developed an electric fail stay unit that can be used both for diaphragm and piston actuators. Fail stay kit uses a signal trip relay and a solenoid valve. Locking time is about same as positioner dead band time.

Max. ambient temperature 60°C.

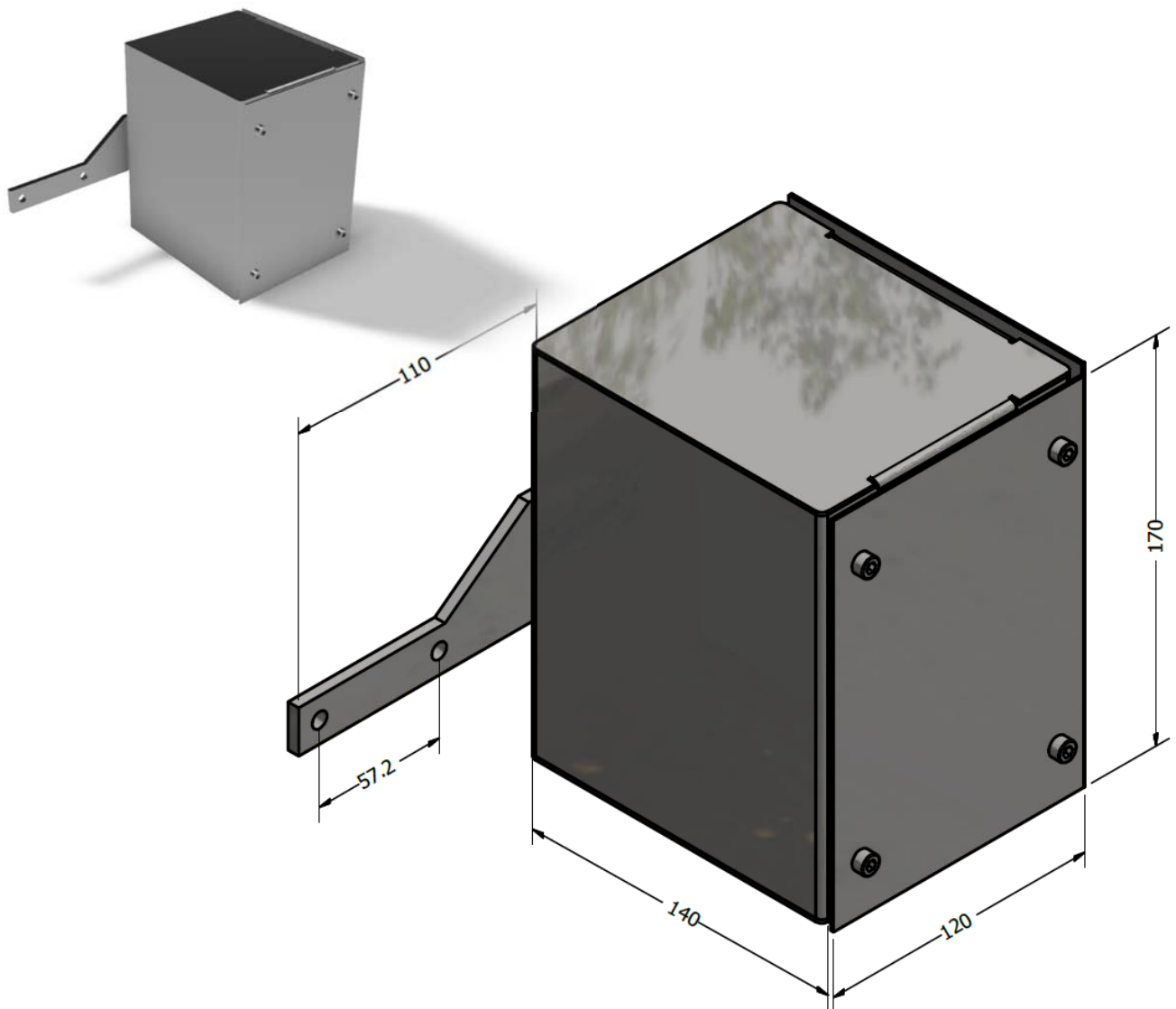

# Electric and pneumatic installation

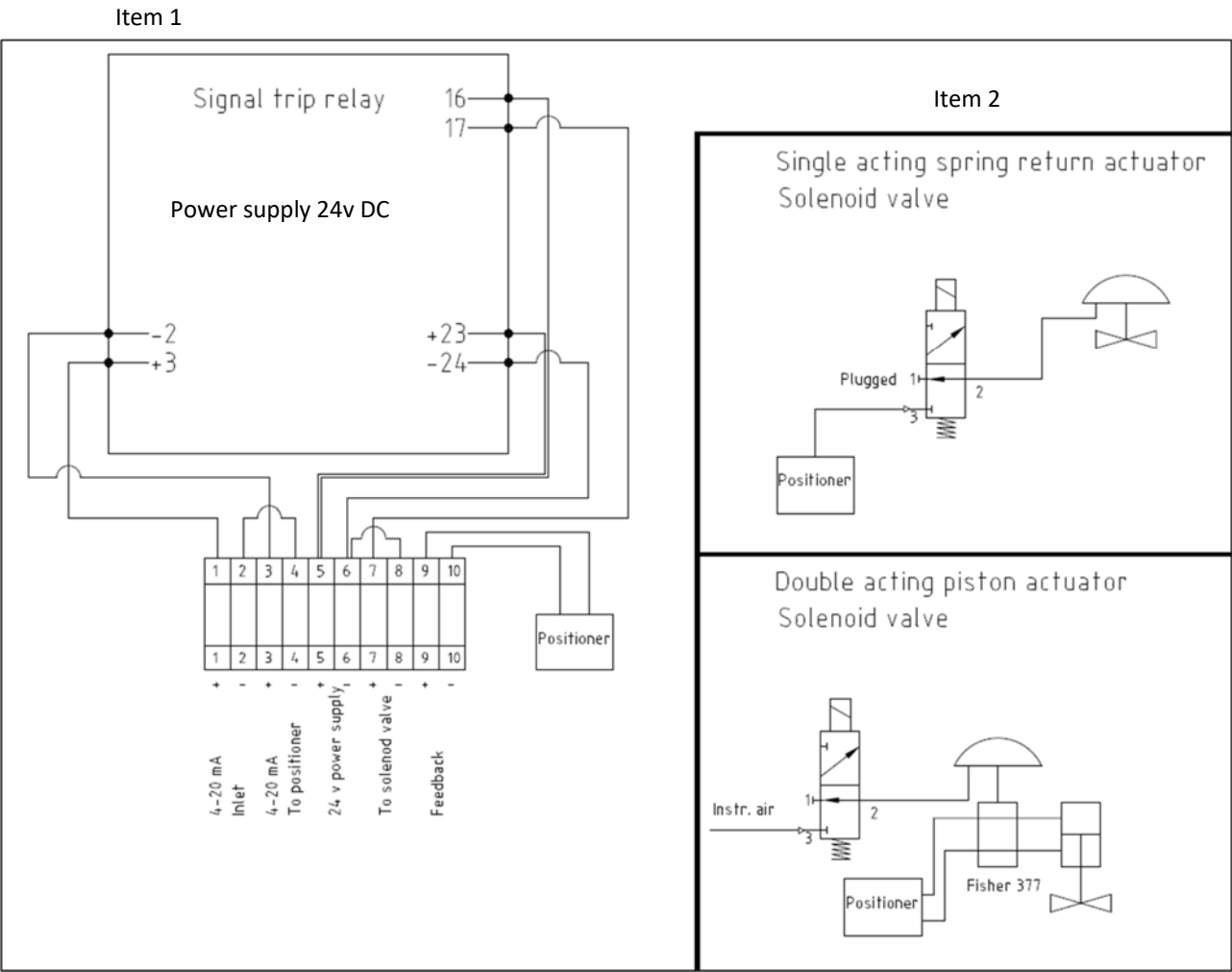

Item 1: Electric trip unit

Item 2: Solenoid Valve

# Parameters

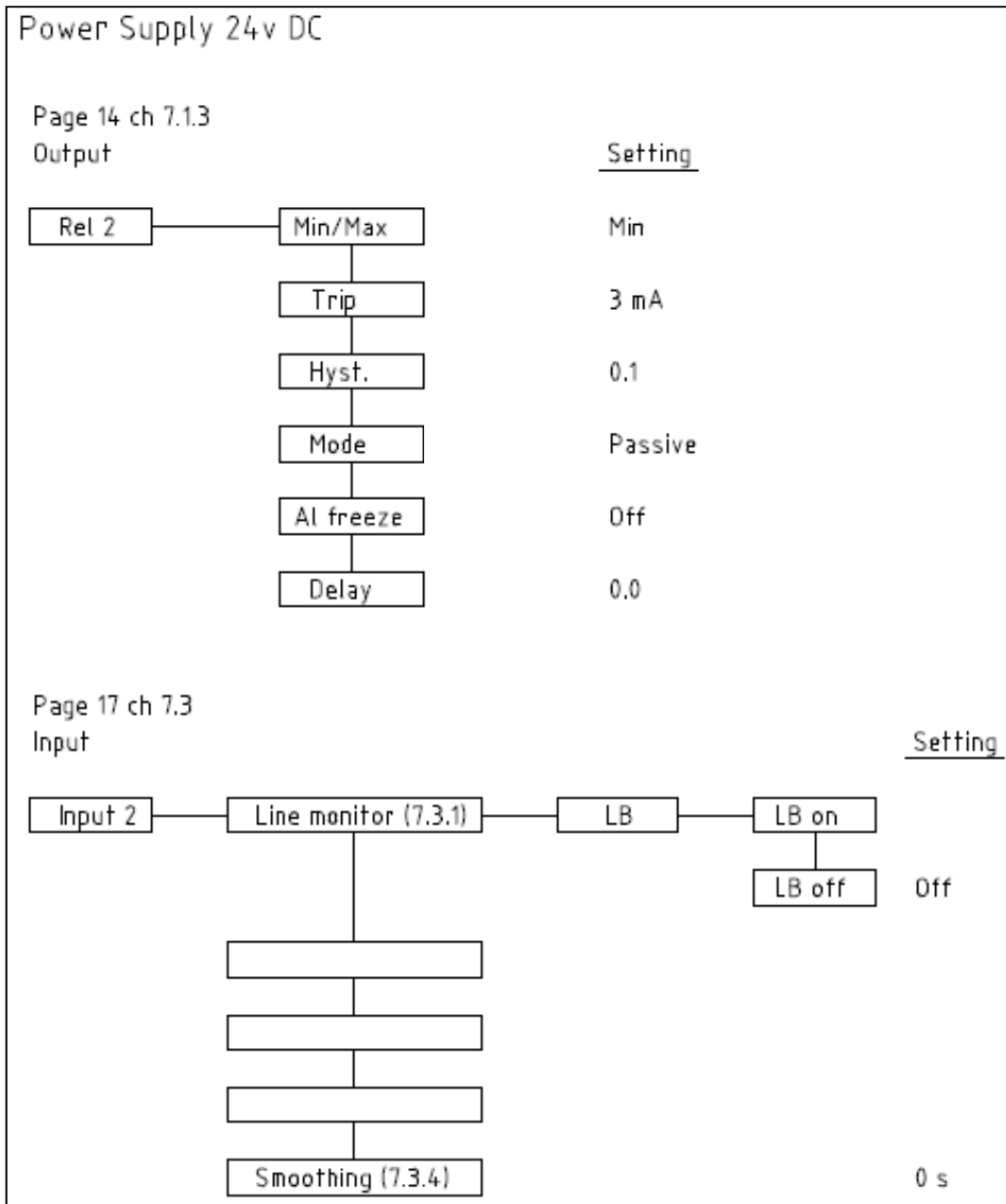

## Changing trip point, etc

**Warning:** A change in device data will change the operation of the device!

Before entering new data into the device, you should ascertain that no danger to the installation will result.

**Note:** In this manual, the parameterisation of the device via the control panel is described. Parameterisation by means of a PC is more convenient.

The necessary K-ADP-USB can be ordered from Pepperl+Fuchs. The PACTware™ operating software and the manual are available on [www.pepperl-fuchs.com](http://www.pepperl-fuchs.com) under Software > PACTware.

Changing parameters is done by using the four keys at the front, OK, ESC and arrows down and up. The information is shown in the display. Entering the system is done by pressing OK and ESC simultaneously at least one to two seconds. No safety code is used. All parameters used except those noted in earlier table are as the factory set up.

Parameterization mode

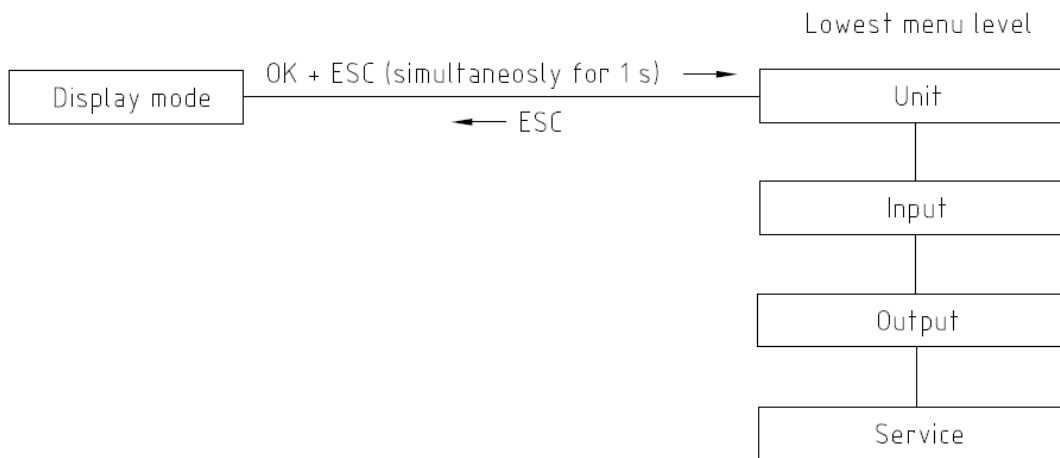

You can return to display mode from any point in the menu in parameterization mode by pressing the ESC key (possibly multiple times). If you do not press any key for 10 minutes in parameterization mode, the device automatically switches back into display mode.

# Saving instructions

## Lowest menu level: select values, enter numeric values

On the lowest level of the menu, you can either select one of several possible values, or enter a number for the individual parameters.

Proceed as follows:

### Main menu parameterization mode

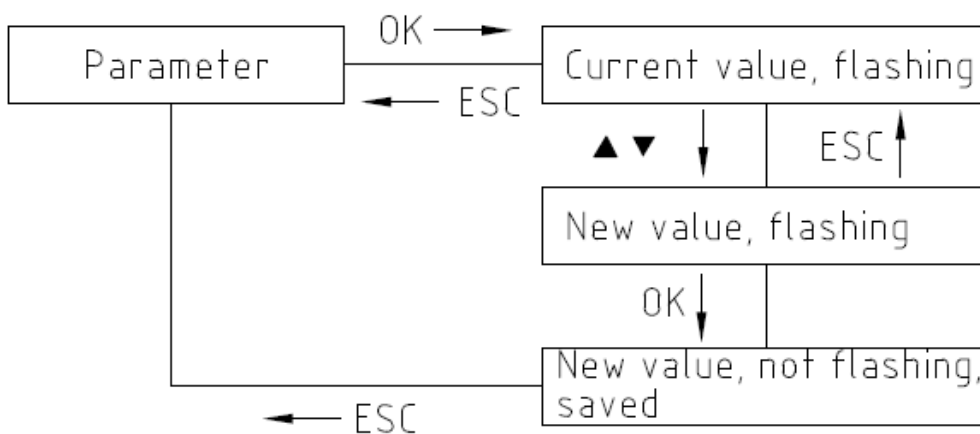

When entering numeric values, please note:

- If you press the up or down keys, the value changes step by step.
- If you hold the up or down keys, the value "rolls" to higher or lower values.
- The algebraic sign changes automatically.
- The decimal point is moved automatically.