



CROSBY EM-SERIES
 SPRING LOADED PRESSURE SAFETY VALVES

Crosby EM-Series Spring Safety Valves are a cost effective, robust and simple overpressure protection solution for gases, steam, liquids and two-phase applications



FEATURES

Design

- Single trim design for steam, gases and liquids
- Enhanced seat tightness
- Simple optimized design brings reduced number of parts and increased reliability
- Restricted lift available to exactly match the application and reduce emissions
- Sturdy light-weight body construction
- Modular concept reduces stock of parts
- Flexible configurations for enhanced control and monitoring
- Available with wireless emissions monitoring

EMC is a conventional design which can accept up to 15% built-up back pressure.

EMH is similar to the EMC except that it is fitted with an open bonnet and is particularly suited for steam or air applications.

EMB is a balanced bellows design fitted with a metallic bellows suitable to accept up to 40% back pressure.

FUNCTIONAL

- Pop action, less than 5% overpressure to full-lift on gases and steam
- Proportional lift on liquids with up to 10% overpressure
- Mechanical lift stop ensures functional stability whatever the fluid is
- Accepts up to 40% variable back-pressure with optional balanced bellows

GENERAL APPLICATION

The Crosby EM Safety Relief Valve provides reliable overpressure protection for industrial applications up to 40 bar (580 psig).

It is fully type-tested for use on gases and liquids with a universal unique trim. Widely available in full compliance with most global codes and standards.

The EM-Series brings the no-nonsense basic solution the industry needs for reliable and tested overpressure protection with minimal maintenance costs.

The design, manufacturing, service and support of the Crosby EM Series valves are backed by more than 150 years of unrivalled experience, and world-class international resources and capabilities.

TECHNICAL DATA

Connections:	EN 1092-1 or ANSI B16.5 flanges
Size inlet:	DN 25 to 100 (1 in. to 4in.)
Pressure ratings:	PN 10 to PN 40, CL 150 to CL 300
Temperature range:	-196 to 427°C (-320 to 800°F)
Set pressure:	0.2 to 40 barg (3 to 580 psig)
Orifice diameter:	23 to 92 mm (0.91 to 3.62 in.)
Body materials:	1.0619, SA216 WCB/WCC, SA352 LCB/LCC, 1.4408, SA351 CF8M/CF3M
Accessories:	Lifting levers Test gag Hardened seat Restricted lift Monitoring Others on request

CROSBY EM-SERIES
 SPRING LOADED PRESSURE SAFETY VALVES

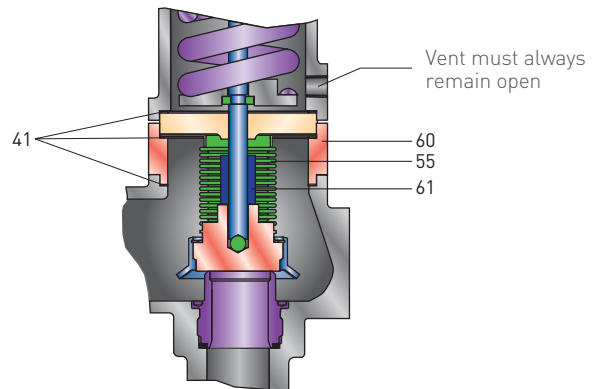
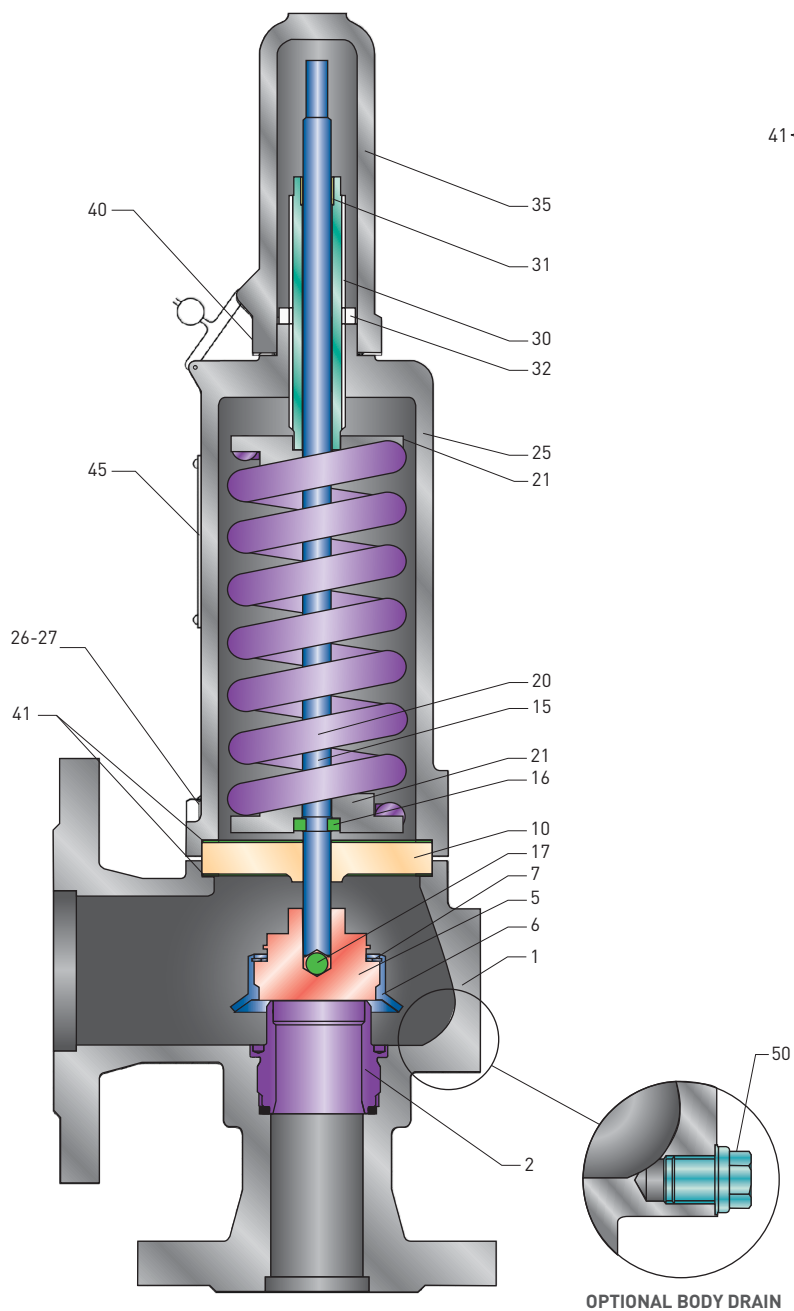

SERIES EMB WITH BALANCED BELLOWS

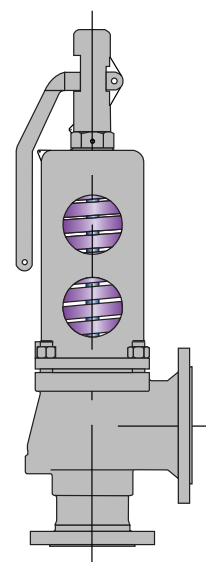

SERIES EMH - CONVENTIONAL WITH OPEN BONNET

CROSBY EM-SERIES

SPRING LOADED PRESSURE SAFETY VALVES

SERIES EM STANDARD MATERIALS OF CONSTRUCTION

Variation	C1	L1	S1	S2
Process Temperature	-29 to +427°C (-20 to 800°F)	-46 to +345°C (-50 to 650°F)	-60 to +427°C (-75 to 800°F)	-196 to +85°C (-320 to 185°F)
Ambient Temperature	-29 to +85°C (-20 to 185°F)	-46 to +85°C (-50 to 185°F)	-55 to +85°C (-67 to +185°F)	-55 to +85°C (-67 to +185°F)
1 Body	SA216 WCB, WCC and 1.0619	SA352 LCB and LCC	SA351 CF8M, CF3M and 1.4408	SA351 CF8M, CF3M and 1.4408
2 Nozzle	SA479-316L and 1.4404	SA479-316L and 1.4404	SA479-316L and 1.4404	SA479-316L and 1.4404
3 Nozzle Seal	Flexible Graphite	Flexible Graphite	Flexible Graphite	Flexible Graphite
5 Disc	SA479-316L and 1.4404	SA479-316L and 1.4404	SA479-316L and 1.4404	SA479-316L and 1.4404
6 Disc Deflector	316L or CF3M	316L or CF3M	316L or CF3M	316L or CF3M
7 Disc Circlip	302 SST	302 SST	302 SST	302 SST
10 Guide	SA479 416 or 1.4005	SA479 416 or 1.4005	SA479 416 or 1.4005	SA479 316L or 1.4404
15 Spindle	SA479-431 or 1.4057	SA479-431 or 1.4057	SA479-431 or 1.4057	SA479-316L and 1.4404
16 Split Collar	SS 17-4 PH	SS 17-4 PH	SS 17-4 PH	SB446 N06625 Gr.1
17 Ball	440C SST	440C SST	440C SST	316L or 1.4404
20 Spring	See table below	See table below	See table below	316
21 Spring Washers	431 or 1.4057	431 or 1.4057	431 or 1.4057	316L or 1.4404
25 Bonnet	as Body	as Body	as Body	as Body
26 Bonnet Stud	SA-193 Gr. B7	SA-193 Gr. B7	SA-193 B8M	SA-193 B8M
27 Bonnet Stud Nut	SA-194 2H	SA-194 2H	SA-194 8M	SA-194 8M
30 Adjusting Bolt	410 or 1.4006	410 or 1.4006	410 or 1.4006	410 or 1.4006
31 Adjusting Bolt Bush	PTFE	PTFE	PTFE	PTFE
32 Adjusting Bolt Nut	316L and 1.4404	316L and 1.4404	316L and 1.4404	316L and 1.4404
35 Threaded Cap ⁽¹⁾	as Body	as Body	as Body	as Body
40 Cap Gasket	Graphite Fiber	Graphite Fiber	Graphite Fiber	Graphite Fiber
41 Guide Gaskets ⁽²⁾	Graphite Fiber	Graphite Fiber	Graphite Fiber	Graphite Fiber
45 Nameplate	316	316	316	316
Optional				
50 Drain Plug	LF2 cl.1 or 1.0566	LF2 cl.1 or 1.0566	F316L or 1.4404	F316L or 1.4404
55 Bellows Assembly	316L	316L	316L	316L
60 Spacer ⁽³⁾	316L and 1.4404	316L and 1.4404	316L and 1.4404	316L and 1.4404
61 Lift Stop ⁽⁴⁾	316L	316L	316L	316L

SPRING MATERIALS

Type	Grade	Operating Temperature
Chrome Vanadium	A231 / A352 / 1.8159	-46 to 232°C (-50 to 450°F)
Tungsten Steel	A681 / 1.2605	-29 to 427°C (-20 to 800°F)
Stainless steel 316	316 / 1.4401	-196 to 260°C (-320 to 500°F)
Inconel® X750	X750 / 2.4669	-60 to 427°C (-76 to 800°F)

NOTES

- Standard cap style. Other styles available as described.
- Total quantity depends on the style of the valve: 2 for standard; +1 if bellows; +1 if high set pressure. See details on high pressure page 6.
- Required for bellows option.
- Required for bellows option.

Inconel® is a mark owned by Special Metals Corporation.

CROSBY EM-SERIES

SPRING LOADED PRESSURE SAFETY VALVES

CAPS AND LIFTING LEVERS

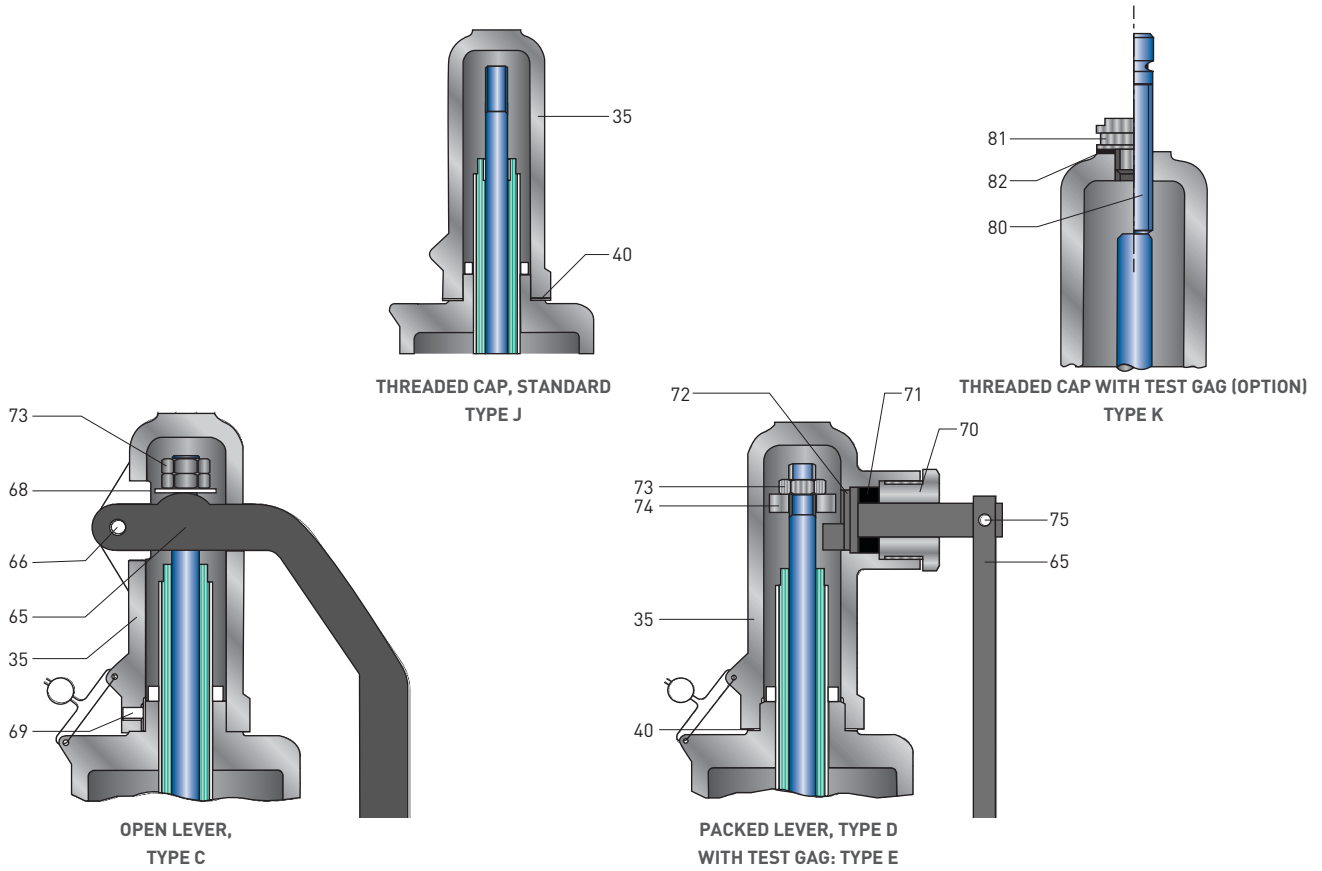

CAPS AND LIFTING LEVERS VARIATIONS

Variation	C1	L1	S1	S2
Process Temperature	-29 to +427°C (-20 to 800°F)	-46 to +345°C (-50 to 650°F)	-60 to +427°C (-75 to 800°F)	-196 to +85°C (-320 to 185°F)
Ambient Temperature	-29 to +85°C (-20 to 185°F)	-46 to +85°C (-50 to 185°F)	-55 to +85°C (-67 to +185°F)	-55 to +85°C (-67 to +185°F)
Nr				
35	Cap SA216 WCB, WCC and 1.0619	SA352 LCB and LCC	SA351 CF8M, CF3M and 1.4408	SA351 CF8M, CF3M and 1.4408
40	Cap Gasket Graphite Fiber	Graphite Fiber	Graphite Fiber	Graphite Fiber
Type C Open Lever				
35	Open Cap SA216 WCB, WCC and 1.0619	SA352 LCB and LCC		
65	Lever SA352 LCB or 1.0619	SA352 LCB or 1.0619	Type C	Type C
66	Pin 301 SST	301 SST	Open Lever	Open Lever
68	Spindle washer 302 SST	302 SST	Not Available	Not Available
69	Grubscrew Stainless Steel	Stainless Steel	in Stainless Steel	in Stainless Steel
73	Spindle Lock Nut 8T or 1.4541	8T or 1.4541		
Type D Packed Lever				
35	Packed Cap SA216 WCB, WCC and 1.0619	SA352 LCB and LCC	SA351 CF8M, CF3M and 1.4408	SA351 CF8M, CF3M and 1.4408
65	Lever AISI 1020	AISI 1020	316L	316L
70	Gland 1.4541 (321 SST)	1.4541 (321 SST)	1.4541 (321 SST)	1.4541 (321 SST)
71	Gland Packing Graphite	Graphite	Graphite	Graphite
72	Eccentric SS 17-4 PH	SS 17-4 PH	SS 17-4 PH	SS 17-4 PH
73	Spindle Lock Nut 8T or 1.4541	8T or 1.4541	8T or 1.4541	8T or 1.4541
74	Spindle Nut 410 or 1.4006	410 or 1.4006	410 or 1.4006	410 or 1.4006
75	Pin 301 SST	301 SST	301 SST	301 SST
40	Cap Gasket Graphite Fiber	Graphite Fiber	Graphite Fiber	Graphite Fiber
Test Gag on Type K (Threaded Cap) or Type E (Packed Lever)				
80	Gag screw 410 or 1.4006	410 or 1.4006	410 or 1.4006	410 or 1.4006
81	Gag plug 410 or 1.4006	410 or 1.4006	410 or 1.4006	410 or 1.4006
82	Gag Plug Gasket Graphite Fiber	Graphite Fiber	Graphite Fiber	Graphite Fiber

CROSBY EM-SERIES

SPRING LOADED PRESSURE SAFETY VALVES

CONVENTIONAL EMC STYLE

The EMC Style is a conventional safety valve: it is the simplest design possible for a safety valve. It has unique features developed from Emerson's more than 150 years of experience in safety valves applications, engineering and maintenance, which bring unique performances to make its use as simple and trouble-free as possible. Being conventional, the EMC Style is mostly suitable for applications with exhaust to atmosphere, or where the backpressure is constant or can be easily compensated. With its enhanced trim design, the EMC Style is fully stable even with up to 15% built-up backpressure.

OPEN BONNET EMH STYLE

The EMH Style is a conventional valve, like the EMC Style, but with an open bonnet. The open bonnet allows the spring to be cooled partially by the atmospheric air, so that the standard Cr-Va spring can be used for higher process temperatures. Please note that during relief, some of the process fluid escapes through the open bonnet. This must be taken into account when considering the location of the valve as the release of process fluid through the bonnet can cause some highly hazardous conditions for people working around. The EMH Style is only suitable for non-hazardous fluids, typically air or steam. It is not suitable for liquid applications.

BALANCED BELLOWS EMB STYLE

The EMB Style is preferred for all the applications where the existing pressure in the exhaust system of the valve varies too much and cannot be compensated. A stainless steel bellows is welded on to the disc to subtract the disc from the influences of the backpressure. The bellows is also a very efficient component to protect the critical sliding faces spindle/guide against grit or any kind of dirt and corrosion that maybe present at the outlet of the valve. As an option, the bellows can also be provided in Inconel® 625 specially enhanced for low cycle fatigue.

SELECTION TABLE

The simple table below can help when selecting which style of the EM Series is more appropriate for the application. However, the selection of a safety valve is a complex process influenced by many variables. Emerson sizing and selection software PRV²SIZE is freely

available to use on line and provides a strong support to select the correct safety valve for your application. In any doubt, you should always consult your local Emerson safety valves specialist for safe advice.

Processed Fluid	Backpressure			Style		
	Built-up	Constant	Super-Imposed Variable	EMC	EMH	EMB
Air	≤15%	Up to total of 80% ⁽¹⁾	0 ⁽²⁾	Preferred	Suitable ⁽³⁾	Acceptable
		Any, total backpressure ≤ 40%		No	No	Preferred
Steam	≤15%	Up to total of 80% ⁽¹⁾	0 ⁽²⁾	Suitable	Preferred ⁽³⁾	Acceptable
		Any, total backpressure ≤ 40%		No	No	Preferred
Other gas/vapor or Liquids	≤15%	Up to total of 80% ⁽¹⁾	0 ⁽²⁾	Preferred	No	Acceptable
		Any, total backpressure ≤ 40%		No	No	Preferred
Corrosive or Dirty Process	≤15%	Up to total of 80% ⁽¹⁾	0 ⁽²⁾	Acceptable	No	Preferred
		Any, total backpressure ≤ 40%		No	No	Preferred

NOTES

% = percentage of the valve set pressure

1. The total backpressure is limited by the rating of the valve outlet. Also, a minimum pressure differential must be observed.
2. In certain conditions, it is possible to safely use the EMC Style with super-imposed variable backpressure, if the operating pressure is low enough.
3. Because of its open bonnet, the EMH Style should always exhaust to atmosphere.

Inconel® is a mark owned by Special Metals Corporation.

CROSBY EM-SERIES

SPRING LOADED PRESSURE SAFETY VALVES

HIGH PRESSURE CONFIGURATIONS

From the size DN 80 (3 in.) and above, the EM Series gets a bonnet extension for high set pressures to suit the necessary length of the spring. This means that the spindle of the 'HP' (High Pressure) configuration is also longer than the standard one.

Low/High Set Pressure Ranges are as Follows:

	Inlet Size	in bar		in psi	
		Low Pressure	High Pressure	Low Pressure	High Pressure
EMC,	DN 80 (3 in.)	< 16.5	>= 16.5	< 240	>= 240
EMH	DN 100 (4 in.)	< 9	>= 9	< 130	>= 130
EMB	DN 80 (3 in.)	< 15.5	>= 15.5	< 225	>= 225
	DN 100 (4 in.)	< 9	>= 9	< 130	>= 130

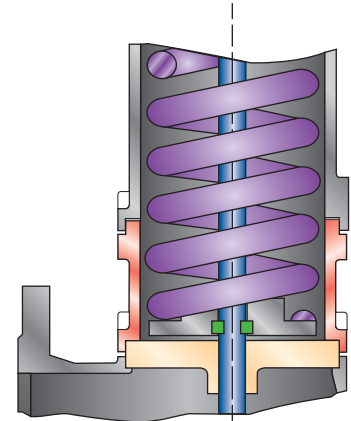

PERFORMANCES

Although with a very simple design, the EM Series offers excellent operational characteristics that give you great flexibility in designing and running your plant. All these are obviously certified by independent third-parties following international codes and standard as detailed.

	Maximum Blowdown	Maximum Overpressure
Gas or Steam	10%	5% ⁽¹⁾
	or 0.3 bar (4.4 psi) whichever is greater	or 0.1 bar (1.5 psi) whichever is greater
Liquids	20%	10%
	or 0.6 bar (8.7 psi) whichever is greater	or 0.1 bar (1.5 psi) whichever is greater

NOTE

1. For balanced EMB with set pressure < 6 barg (87 psig): 10%

CERTIFICATIONS

The EM Series valves have been extensively tested during development stage to ensure reliable and dependable operation. Functional and flow characteristics detailed in this datasheet have been fully certified in accordance to:

- **ISO EN 4126-1** Gas, Steam and Liquids

The valves are also fully certified in compliance with:

- **PED 2014-68-EU** EU Pressure Equipment Directive
- **ATEX 2014-34-EU** EU Explosive Atmosphere Directive

OPTIONS AND ACCESSORIES

Restricted Lift

The purpose of a restricted lift safety valve is to more closely match the required capacity of the protected equipment with the rated capacity of the valve. To restrict the lift, a stainless steel washer of the necessary thickness is added on top of the disc. This washer creates a physical stop with the guide, at a lower lift value than the disc and guide alone. This option is available for all designs and all process fluids. Be aware that some codes or standards have defined requirements for restricted lift valves. The restricted lifts available for the EM Series comply with all requirements from the codes and standard that accept them.

Lift Restrictions Available:

DN 25 x 40 (1 in. x 1½ in.)	80% down to 40% of full lift
Larger sizes	80% down to 30% of full lift

Please refer to pages 8-9 for the effects of the lift restriction on the flow coefficient of the valve, and therefore its capacity.

Body Drain

All installation practices, codes and standards recommend that the discharge piping from a safety valve shall be self-draining. This is to prevent any accumulation of condensates or rain water in the body of the valve. Condensates shall never be left to accumulate in the body of a safety valve. If required, a body drain can be added to any configuration of the EM Series. A drain pipe can then be connected to avoid any accumulation of condensates.

The threads of the drain can be either NPT or metric ISO 228.

Bug Screen

For the EMB style valves fitted with a balanced bellows, it is extremely important to keep the bonnet of the valve vented to atmosphere all the time. The vent hole in the bonnet should preferably be piped to a safe location to avoid hazardous process fluid to escape in the vicinity of the valve in case of bellows failure. The vent hole is threaded per ISO 228 (metric) or NPT. If the process fluid is not hazardous, a bug screen can be provided instead. While enabling the free venting of the bonnet to atmosphere, it prevents insects entering and settling inside the bonnet.

Government Ring

This ring is adjusted to the right length once the valve has been set and tested. It prevents to screw the adjusting bolt too far. It also makes it easier to re-set the valve at its correct set pressure. Please note that a full testing as described in the EM Series manual is still necessary to confirm that the valve has been correctly set.

Emissions Monitoring

The EM Series can also be fitted with the Rosemount™ 708 wireless acoustic transmitter to provide easy monitoring of overpressure events and also potential seat leakages.

BODY DRAIN

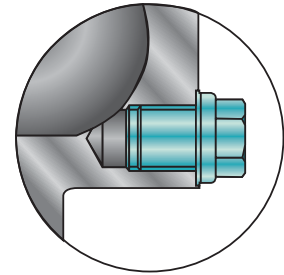

BUG SCREEN

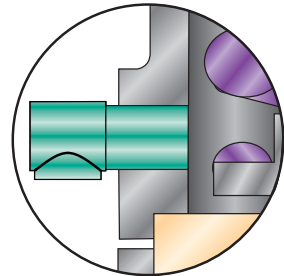

GOVERNMENT RING

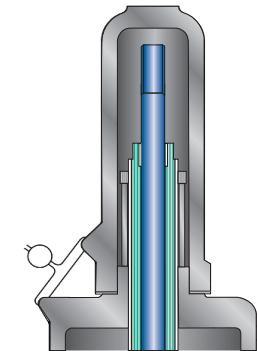

CROSBY EM-SERIES

SPRING LOADED PRESSURE SAFETY VALVES

SIZING DATA PER ISO EN 4126

K_{dr} = Certified de-rated flow coefficient (includes 10% safety factor)
 P_1 = Total flowing pressure, in absolute unit
 = Set + overpressure - inlet losses + atmospheric pressure

P_2 = Total backpressure, in absolute unit
 Set = Set pressure in relative/gauge unit
 p_2 = Total backpressure, in relative/gauge unit

Gas or Steam

CONVENTIONAL VALVES: EMC AND EMH

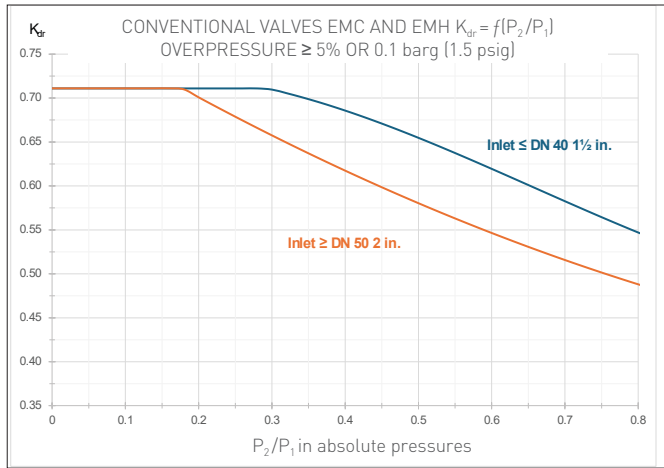

BALANCED BELLOWS VALVES: EMB

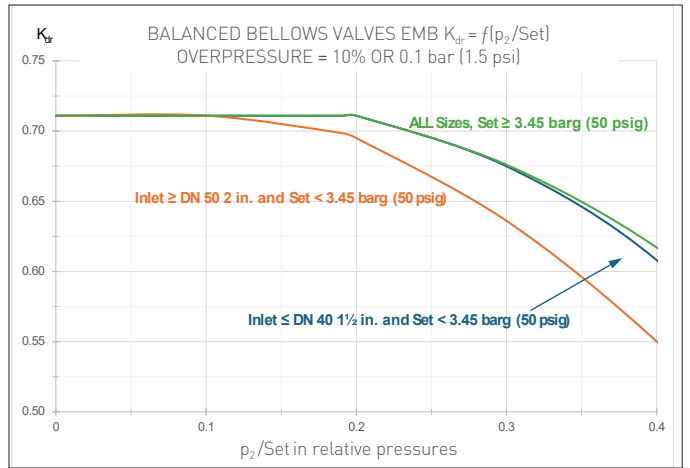

ALL VALVES EMC, EMH AND EMB ON GAS OR STEAM

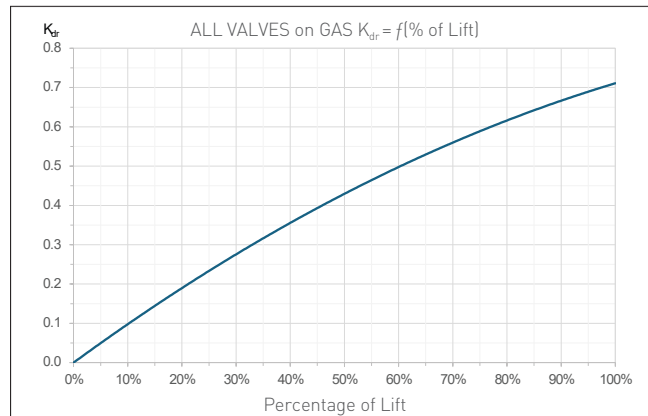

Liquids

All valves EMC, EMH and EMB
 $K_{dr} = 0.453$ at 10% overpressure
 or 0.1 barg (1.5 psig)

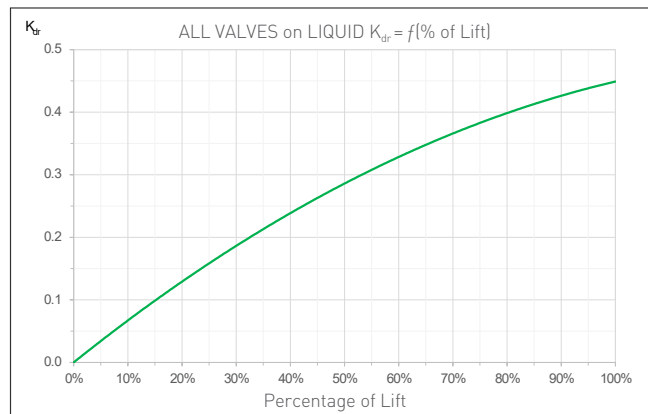

CERTIFIED FLOW AREAS

DN	25 x 40	32 x 50	40 x 65	50 x 80	65 x 100	80 x 125	100 x 150
mm ²	415	660	1075	1662	2827	4301	6648
in ²	0.64	1.02	1.67	2.58	4.38	6.67	10.3

CROSBY EM-SERIES

SPRING LOADED PRESSURE SAFETY VALVES

SIZING DATA PER API STD 520

K = Certified de-rated flow coefficient (includes 10% safety factor)
 P_1 = Total flowing pressure, in absolute unit
 = Set + overpressure - inlet losses + atmospheric pressure

P_2 = Total backpressure, in absolute unit
 Set = Set pressure in relative/gauge unit
 p_2 = Total backpressure, in relative/gauge unit

Air or Gas

For all EM variations: $K = 0.711$ at 10% overpressure or 0.2 bar (3 psi)

CONVENTIONAL VALVES: EMC AND EMH

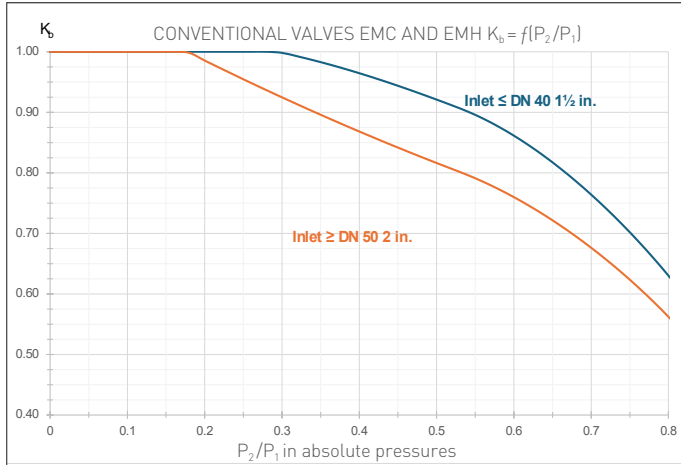

BALANCED BELLOWS VALVES: EMB

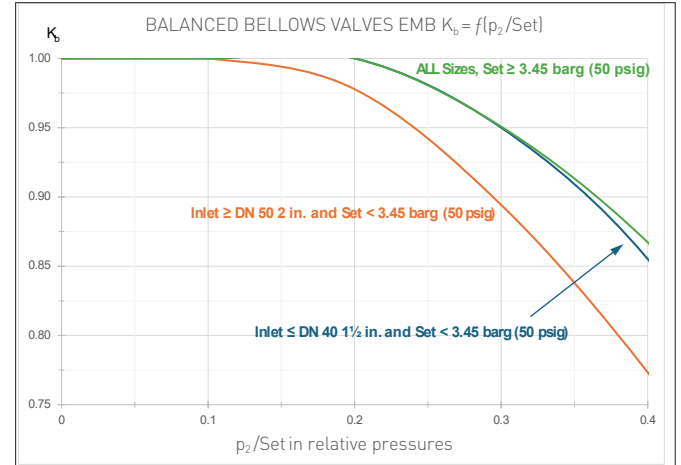

Liquids

All valves EMC, EMH and EMB
 $K = 0.453$ at 10% overpressure
 or 0.2 barg (3 psig)

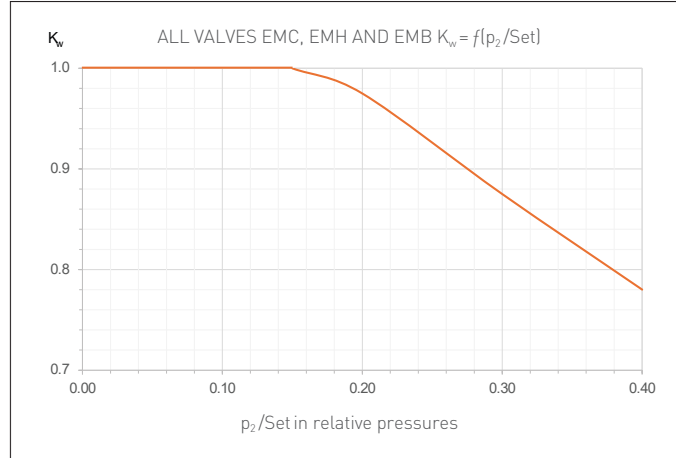

CERTIFIED FLOW AREAS

NPS	1 x 1½	1¼ x 2	1½ x 2½	2 x 3	2½ x 4	3 x 5	4 x 6
mm ²	415	660	1075	1662	2827	4301	6648
in ²	0.64	1.02	1.67	2.58	4.38	6.67	10.3

CROSBY EM-SERIES

SPRING LOADED PRESSURE SAFETY VALVES

PRESSURE AND TEMPERATURE RATINGS

WITH EN 1092-1 FLANGED CONNECTIONS

Size, DN	Material	Inlet	Lowest to	Maximum Set Pressure, bar (psig)									Outlet Flange Backpressure			
				All Styles: EMC, EMH and EMB									Limit at +50°C (120°F) ^[1]			
				+50°C (120°F)	+85°C (185°F)	+100°C (210°F)	+150°C (300°F)	+200°C (390°F)	+250°C (482°F)	+300°C (570°F)	+345°C (650°F)	+427°C (800°F)	EMC		EMB ^[2]	
										PN 10	PN 16	PN 10	PN 16			
25 x 40 to 50 x 80	C1	PN10	-29°C (-20°F)	10 (145)	9.4 (136)	9.2 (133)	8.8 (128)	8.3 (120)	7.6 (110)	6.9 (100)	6.4 (93)	4.5 (65)	8 (116)	8 (116)	4 (58)	4 (58)
		PN16	-29°C (-20°F)	16 (232)	15 (218)	14.8 (215)	14 (203)	13.3 (193)	12.1 (175)	11 (160)	10.2 (148)	7.4 (107)	10 (145)	12.8 (186)	6.4 (93)	6.4 (93)
		PN25	-29°C (-20°F)	25 (363)	23.5 (341)	23.2 (336)	22 (319)	20.8 (302)	19 (276)	17.2 (249)	16 (232)	11.5 (167)	10 (145)	16 (232)	10 (145)	10 (145)
		PN40	-29°C (-20°F)	40 (580)	37.7 (547)	37.1 (538)	35.2 (510)	33.3 (483)	30.4 (441)	27.6 (400)	25.7 (373)	18.5 (268)	10 (145)	16 (232)	10 (145)	16 (232)
	L1	PN10	-46°C (-50°F)	10 (145)	9.4 (136)	9.2 (133)	8.8 (128)	8.3 (120)	7.6 (110)	6.9 (100)	6.4 (93)	----	8 (116)	8 (116)	4 (58)	4 (58)
		PN16	-46°C (-50°F)	16 (232)	15 (218)	14.8 (215)	14 (203)	13.3 (193)	12.1 (175)	11 (160)	10.2 (148)	----	10 (145)	12.8 (186)	6.4 (93)	6.4 (93)
		PN25	-46°C (-50°F)	25 (363)	23.5 (341)	23.2 (336)	22 (319)	20.8 (302)	19 (276)	17.2 (249)	16 (232)	----	10 (145)	16 (232)	10 (145)	10 (145)
		PN40	-46°C (-50°F)	40 (580)	37.7 (547)	37.1 (538)	35.2 (510)	33.3 (483)	30.4 (441)	27.6 (400)	25.7 (373)	----	10 (145)	16 (232)	10 (145)	16 (232)
	S1	PN10	-60°C (-75°F)	10 (145)	10 (145)	10 (145)	9 (131)	8.4 (122)	7.9 (115)	7.4 (107)	7.1 (103)	6.8 (99)	8 (116)	8 (116)	4 (58)	4 (58)
		PN16	-60°C (-75°F)	16 (232)	16 (232)	16 (232)	14.5 (210)	13.4 (194)	12.7 (184)	11.8 (171)	11.4 (165)	10.9 (158)	10 (145)	12.8 (186)	6.4 (93)	6.4 (93)
		PN25	-60°C (-75°F)	25 (363)	25 (363)	25 (363)	22.7 (329)	21 (305)	19.8 (287)	18.5 (268)	17.8 (258)	17.1 (248)	10 (145)	16 (232)	10 (145)	10 (145)
		PN40	-60°C (-75°F)	40 (580)	40 (580)	40 (580)	36.3 (526)	33.7 (489)	31.8 (461)	29.7 (431)	28.5 (413)	27.3 (396)	10 (145)	16 (232)	10 (145)	16 (232)
S2	PN10	-196°C (-320°F)	10 (145)	10 (145)	----	----	----	----	----	----	----	8 (116)	8 (116)	----	----	
	PN16	-196°C (-320°F)	16 (232)	16 (232)	----	----	----	----	----	----	----	10 (145)	12.8 (186)	----	----	
	PN25	-196°C (-320°F)	25 (363)	25 (363)	----	----	----	----	----	----	----	10 (145)	16 (232)	----	----	
	PN40	-196°C (-320°F)	40 (580)	40 (580)	----	----	----	----	----	----	----	10 (145)	16 (232)	----	----	
65 x 100	C1	PN10	-29°C (-20°F)	10 (145)	9.4 (136)	9.2 (133)	8.8 (128)	8.3 (120)	7.6 (110)	6.9 (100)	6.4 (93)	4.5 (65)	8 (116)	8 (116)	4 (58)	4 (58)
		PN16	-29°C (-20°F)	16 (232)	15 (218)	14.8 (215)	14 (203)	13.3 (193)	12.1 (175)	11 (160)	10.2 (148)	7.4 (107)	10 (145)	12.8 (186)	6.4 (93)	6.4 (93)
		PN25	-29°C (-20°F)	25 (363)	23.5 (341)	23.2 (336)	22 (319)	20.8 (302)	19 (276)	17.2 (249)	16 (232)	11.5 (167)	10 (145)	16 (232)	10 (145)	10 (145)
		PN40	-29°C (-20°F)	40 (580)	37.7 (547)	37.1 (538)	35.2 (510)	33.3 (483)	30.4 (441)	27.6 (400)	25.7 (373)	18.5 (268)	10 (145)	16 (232)	10 (145)	16 (232)
	L1	PN10	-46°C (-50°F)	10 (145)	9.4 (136)	9.2 (133)	8.8 (128)	8.3 (120)	7.6 (110)	6.9 (100)	6.4 (93)	----	8 (116)	8 (116)	4 (58)	4 (58)
		PN16	-46°C (-50°F)	16 (232)	15 (218)	14.8 (215)	14 (203)	13.3 (193)	12.1 (175)	11 (160)	10.2 (148)	----	10 (145)	12.8 (186)	6.4 (93)	6.4 (93)
		PN25	-46°C (-50°F)	25 (363)	23.5 (341)	23.2 (336)	22 (319)	20.8 (302)	19 (276)	17.2 (249)	16 (232)	----	10 (145)	16 (232)	10 (145)	10 (145)
		PN40	-46°C (-50°F)	40 (580)	37.7 (547)	37.1 (538)	35.2 (510)	33.3 (483)	30.4 (441)	27.6 (400)	25.7 (373)	----	10 (145)	16 (232)	10 (145)	16 (232)
	S1	PN10	-60°C (-75°F)	10 (145)	10 (145)	10 (145)	9 (131)	8.4 (122)	7.9 (115)	7.4 (107)	7.1 (103)	6.8 (99)	8 (116)	8 (116)	4 (58)	4 (58)
		PN16	-60°C (-75°F)	16 (232)	16 (232)	16 (232)	14.5 (210)	13.4 (194)	12.7 (184)	11.8 (171)	11.4 (165)	10.9 (158)	10 (145)	12.8 (186)	6.4 (93)	6.4 (93)
		PN25	-60°C (-75°F)	25 (363)	25 (363)	25 (363)	22.7 (329)	21 (305)	19.8 (287)	18.5 (268)	17.8 (258)	17.1 (248)	10 (145)	16 (232)	10 (145)	10 (145)
		PN40	-60°C (-75°F)	35 (508)	35 (508)	35 (508)	35 (508)	33.7 (489)	31.8 (461)	29.7 (431)	28.5 (413)	27.3 (396)	10 (145)	16 (232)	10 (145)	14 (203)
S2	PN10	-196°C (-320°F)	10 (145)	10 (145)	----	----	----	----	----	----	----	8 (116)	8 (116)	----	----	
	PN16	-196°C (-320°F)	16 (232)	16 (232)	----	----	----	----	----	----	----	10 (145)	12.8 (186)	----	----	
	PN25	-196°C (-320°F)	25 (363)	25 (363)	----	----	----	----	----	----	----	10 (145)	16 (232)	----	----	
	PN40	-196°C (-320°F)	35 (508)	35 (508)	----	----	----	----	----	----	----	10 (145)	16 (232)	----	----	
80 x 125	C1	PN10	-29°C (-20°F)	10 (145)	9.4 (136)	9.2 (133)	8.8 (128)	8.3 (120)	7.6 (110)	6.9 (100)	6.4 (93)	4.5 (65)	8 (116)	8 (116)	4 (58)	4 (58)
		PN16	-29°C (-20°F)	16 (232)	15 (218)	14.8 (215)	14 (203)	13.3 (193)	12.1 (175)	11 (160)	10.2 (148)	7.4 (107)	10 (145)	12.8 (186)	6.4 (93)	6.4 (93)
		PN25	-29°C (-20°F)	25 (363)	23.5 (341)	23.2 (336)	22 (319)	20.8 (302)	19 (276)	17.2 (249)	16 (232)	11.5 (167)	10 (145)	16 (232)	10 (145)	10 (145)
		PN40	-29°C (-20°F)	40 (580)	37.7 (547)	37.1 (538)	35.2 (510)	33.3 (483)	30.4 (441)	27.6 (400)	25.7 (373)	18.5 (268)	10 (145)	16 (232)	10 (145)	16 (232)
	L1	PN10	-46°C (-50°F)	10 (145)	9.4 (136)	9.2 (133)	8.8 (128)	8.3 (120)	7.6 (110)	6.9 (100)	6.4 (93)	----	8 (116)	8 (116)	4 (58)	4 (58)
		PN16	-46°C (-50°F)	16 (232)	15 (218)	14.8 (215)	14 (203)	13.3 (193)	12.1 (175)	11 (160)	10.2 (148)	----	10 (145)	12.8 (186)	6.4 (93)	6.4 (93)
		PN25	-46°C (-50°F)	25 (363)	23.5 (341)	23.2 (336)	22 (319)	20.8 (302)	19 (276)	17.2 (249)	16 (232)	----	10 (145)	16 (232)	10 (145)	10 (145)
		PN40	-46°C (-50°F)	40 (580)	37.7 (547)	37.1 (538)	35.2 (510)	33.3 (483)	30.4 (441)	27.6 (400)	25.7 (373)	----	10 (145)	16 (232)	10 (145)	16 (232)
	S1	PN10	-60°C (-75°F)	10 (145)	10 (145)	10 (145)	9 (131)	8.4 (122)	7.9 (115)	7.4 (107)	7.1 (103)	6.8 (99)	8 (116)	8 (116)	4 (58)	4 (58)
		PN16	-60°C (-75°F)	16 (232)	16 (232)	16 (232)	14.5 (210)	13.4 (194)	12.7 (184)	11.8 (171)	11.4 (165)	10.9 (158)	10 (145)	12.8 (186)	6.4 (93)	6.4 (93)
		PN25	-60°C (-75°F)	25 (363)	25 (363)	25 (363)	22.7 (329)	21 (305)	19.8 (287)	18.5 (268)	17.8 (258)	17.1 (248)	10 (145)	16 (232)	10 (145)	10 (145)
		PN40	-60°C (-75°F)	32 (464)	32 (464)	32 (464)	32 (464)	32 (464)	31.8 (461)	29.7 (431)	28.5 (413)	27.3 (396)	10 (145)	16 (232)	10 (145)	12.8 (186)
S2	PN10	-196°C (-320°F)	10 (145)	10 (145)	----	----	----	----	----	----	----	8 (116)	8 (116)	----	----	
	PN16	-196°C (-320°F)	16 (232)	16 (232)	----	----	----	----	----	----	----	10 (145)	12.8 (186)	----	----	
	PN25	-196°C (-320°F)	25 (363)	25 (363)	----	----	----	----	----	----	----	10 (145)	16 (232)	----	----	
	PN40	-196°C (-320°F)	32 (464)	32 (464)	----	----	----	----	----	----	----	10 (145)	16 (232)	----	----	

NOTE

- Outlet pressure for temperatures above 50°C (120°F) should not exceed the EN 1092-1 flange rating.
- Maximum backpressure on the balanced bellows version must also be limited to 40% of the set pressure of the valve.

MINIMUM SET PRESSURES

EMC and EMH: 0.2 barg (3 psig)

EMB: 2.0 barg (29 psig)

CROSBY EM-SERIES

SPRING LOADED PRESSURE SAFETY VALVES

PRESSURE AND TEMPERATURE RATINGS

WITH EN 1092-1 FLANGED CONNECTIONS (CONTINUED)

Size, DN	Material	Inlet	Lowest to	Maximum Set Pressure, bar (psig) All Styles: EMC, EMH and EMB									Outlet Flange Backpressure Limit at +50°C (120°F) ⁽¹⁾			
				+50°C (120°F)	+85°C (185°F)	+100°C (210°F)	+150°C (300°F)	+200°C (390°F)	+250°C (482°F)	+300°C (570°F)	+345°C (650°F)	+427°C (800°F)	EMC		EMB ⁽²⁾	
100 x 150	C1	PN10	-29°C (-20°F)	10 (145)	9.4 (136)	9.2 (133)	8.8 (128)	8.3 (120)	7.6 (110)	6.9 (100)	6.4 (93)	4.5 (65)	8 (116)	8 (116)	4 (58)	4 (58)
		PN16	-29°C (-20°F)	16 (232)	15 (218)	14.8 (215)	14 (203)	13.3 (193)	12.1 (175)	11 (160)	10.2 (148)	7.4 (107)	10 (145)	12.8 (186)	6.4 (93)	6.4 (93)
		PN25	-29°C (-20°F)	25 (363)	23.5 (341)	23.2 (336)	22 (319)	20.8 (302)	19 (276)	17.2 (249)	16 (232)	11.5 (167)	10 (145)	16 (232)	10 (145)	10 (145)
		PN40	-29°C (-20°F)	40 (580)	37.7 (547)	37.1 (538)	35.2 (510)	33.3 (483)	30.4 (441)	27.6 (400)	25.7 (373)	18.5 (268)	10 (145)	16 (232)	10 (145)	16 (232)
	L1	PN10	-46°C (-50°F)	10 (145)	9.4 (136)	9.2 (133)	8.8 (128)	8.3 (120)	7.6 (110)	6.9 (100)	6.4 (93)	----	8 (116)	8 (116)	4 (58)	4 (58)
		PN16	-46°C (-50°F)	16 (232)	15 (218)	14.8 (215)	14 (203)	13.3 (193)	12.1 (175)	11 (160)	10.2 (148)	----	10 (145)	12.8 (186)	6.4 (93)	6.4 (93)
		PN25	-46°C (-50°F)	25 (363)	23.5 (341)	23.2 (336)	22 (319)	20.8 (302)	19 (276)	17.2 (249)	16 (232)	----	10 (145)	16 (232)	10 (145)	10 (145)
		PN40	-46°C (-50°F)	40 (580)	37.7 (547)	37.1 (538)	35.2 (510)	33.3 (483)	30.4 (441)	27.6 (400)	25.7 (373)	----	10 (145)	16 (232)	10 (145)	16 (232)
	S1	PN10	-60°C (-75°F)	10 (145)	10 (145)	10 (145)	9 (131)	8.4 (122)	7.9 (115)	7.4 (107)	7.1 (103)	6.8 (99)	8 (116)	8 (116)	4 (58)	4 (58)
		PN16	-60°C (-75°F)	16 (232)	16 (232)	16 (232)	14.5 (210)	13.4 (194)	12.7 (184)	11.8 (171)	11.4 (165)	10.9 (158)	10 (145)	12.8 (186)	6.4 (93)	6.4 (93)
		PN25	-60°C (-75°F)	25 (363)	25 (363)	25 (363)	22.7 (329)	21 (305)	19.8 (287)	18.5 (268)	17.8 (258)	17.1 (248)	10 (145)	16 (232)	10 (145)	10 (145)
		PN40	-60°C (-75°F)	25 (363)	25 (363)	25 (363)	25 (363)	25 (363)	25 (363)	25 (363)	25 (363)	25 (363)	10 (145)	16 (232)	10 (145)	10 (145)
S2	PN10	-196°C (-320°F)	10 (145)	10 (145)	----	----	----	----	----	----	----	8.0 (116)	8 (116)	----	----	
	PN16	-196°C (-320°F)	16 (232)	16 (232)	----	----	----	----	----	----	----	10.0 (145)	12.8 (186)	----	----	
	PN25	-196°C (-320°F)	25 (363)	25 (363)	----	----	----	----	----	----	----	10.0 (145)	16 (232)	----	----	
	PN40	-196°C (-320°F)	25 (363)	25 (363)	----	----	----	----	----	----	----	10.0 (145)	16 (232)	----	----	

WITH ANSI B16.5 FLANGED CONNECTIONS

Size, inches	Material	Inlet	Lowest to	Maximum Set Pressure, bar (psig) All Styles: EMC, EMH and EMB									Outlet Flange Backpressure Limit at +38°C (100°F) ⁽²⁾		
				+38°C (100°F)	+50°C (120°F)	+85°C (185°F)	+100°C (210°F)	+150°C (300°F)	+200°C (390°F)	+250°C (482°F)	+300°C (570°F)	+345°C (650°F)	+427°C (800°F)	EMC 150#	EMB ⁽²⁾ 150#
1 x 1½ to 2 x 3	C1	CL 150	-29°C (-20°F)	19.8 (287)	19.5 (283)	18.2 (264)	17.7 (257)	15.8 (229)	13.8 (200)	12.1 (175)	10.2 (148)	8.6 (125)	5.5 (80)	15.8 (229)	7.9 (115)
		CL 300	-29°C (-20°F)	40 (580)	40 (580)	40 (580)	40 (580)	40 (580)	40 (580)	40 (580)	40 (580)	40 (580)	28.3 (410)	16 (232)	16 (232)
	L1	CL 150	-46°C (-50°F)	19.8 (287)	19.5 (283)	18.2 (264)	17.7 (257)	15.8 (229)	13.8 (200)	12.1 (175)	10.2 (148)	8.6 (125)	----	15.8 (229)	7.9 (115)
		CL 300	-46°C (-50°F)	40 (580)	40 (580)	40 (580)	40 (580)	40 (580)	40 (580)	40 (580)	40 (580)	40 (580)	----	16 (232)	16 (232)
	S1	CL 150	-60°C (-75°F)	19 (276)	18.4 (267)	17.2 (249)	16.2 (235)	14.8 (215)	13.7 (199)	12.1 (175)	10.2 (148)	8.6 (125)	5.5 (80)	15.2 (220)	7.6 (110)
		CL 300	-60°C (-75°F)	40 (580)	40 (580)	40 (580)	40 (580)	38.5 (558)	35.7 (518)	33.4 (484)	31.6 (458)	30.3 (439)	28.9 (419)	16 (232)	16 (232)
	S2	CL 150	-196°C (-320°F)	19 (276)	18.4 (267)	17.2 (249)	----	----	----	----	----	----	----	15.2 (220)	----
		CL 300	-196°C (-320°F)	40 (580)	40 (580)	40 (580)	----	----	----	----	----	----	----	16 (232)	----
2½ x 4	C1	CL 150	-29°C (-20°F)	19.8 (287)	19.5 (283)	18.2 (264)	17.7 (257)	15.8 (229)	13.8 (200)	12.1 (175)	10.2 (148)	8.6 (125)	5.5 (80)	15.8 (229)	7.9 (115)
		CL 300	-29°C (-20°F)	40 (580)	40 (580)	40 (580)	40 (580)	40 (580)	40 (580)	40 (580)	40 (580)	40 (580)	28.3 (410)	16 (232)	16 (232)
	L1	CL 150	-46°C (-50°F)	19.8 (287)	19.5 (283)	18.2 (264)	17.7 (257)	15.8 (229)	13.8 (200)	12.1 (175)	10.2 (148)	8.6 (125)	----	15.8 (229)	7.9 (115)
		CL 300	-46°C (-50°F)	40 (580)	40 (580)	40 (580)	40 (580)	40 (580)	40 (580)	40 (580)	40 (580)	40 (580)	----	16 (232)	16 (232)
	S1	CL 150	-60°C (-75°F)	19 (276)	18.4 (267)	17.2 (249)	16.2 (235)	14.8 (215)	13.7 (199)	12.1 (175)	10.2 (148)	8.6 (125)	5.5 (80)	15.2 (220)	7.6 (110)
		CL 300	-60°C (-75°F)	35 (508)	35 (508)	35 (508)	35 (508)	35 (508)	35 (508)	33.4 (484)	31.6 (458)	30.3 (439)	28.9 (419)	16 (232)	14 (203)
	S2	CL 150	-196°C (-320°F)	19 (276)	18.4 (267)	17.2 (249)	----	----	----	----	----	----	----	15.2 (220)	----
		CL 300	-196°C (-320°F)	35 (508)	35 (508)	35 (508)	----	----	----	----	----	----	----	16 (232)	----
3 x 5	C1	CL 150	-29°C (-20°F)	19.8 (287)	19.5 (283)	18.2 (264)	17.7 (257)	15.8 (229)	13.8 (200)	12.1 (175)	10.2 (148)	8.6 (125)	5.5 (80)	15.8 (229)	7.9 (115)
		CL 300	-29°C (-20°F)	40 (580)	40 (580)	40 (580)	40 (580)	40 (580)	40 (580)	40 (580)	40 (580)	40 (580)	28.3 (410)	16 (232)	16 (232)
	L1	CL 150	-46°C (-50°F)	19.8 (287)	19.5 (283)	18.2 (264)	17.7 (257)	15.8 (229)	13.8 (200)	12.1 (175)	10.2 (148)	8.6 (125)	----	15.8 (229)	7.9 (115)
		CL 300	-46°C (-50°F)	40 (580)	40 (580)	40 (580)	40 (580)	40 (580)	40 (580)	40 (580)	40 (580)	40 (580)	----	16 (232)	16 (232)
	S1	CL 150	-60°C (-75°F)	19 (276)	18.4 (267)	17.2 (249)	16.2 (235)	14.8 (215)	13.7 (199)	12.1 (175)	10.2 (148)	8.6 (125)	5.5 (80)	15.2 (220)	7.6 (110)
		CL 300	-60°C (-75°F)	32 (464)	32 (464)	32 (464)	32 (464)	32 (464)	32 (464)	32 (464)	31.6 (458)	30.3 (439)	28.9 (419)	16 (232)	12.8 (186)
	S2	CL 150	-196°C (-320°F)	19 (276)	18.4 (267)	17.2 (249)	----	----	----	----	----	----	----	15.2 (220)	----
		CL 300	-196°C (-320°F)	32 (464)	32 (464)	32 (464)	----	----	----	----	----	----	----	16 (232)	----
4 x 6	C1	CL 150	-29°C (-20°F)	19.8 (287)	19.5 (283)	18.2 (264)	17.7 (257)	15.8 (229)	13.8 (200)	12.1 (175)	10.2 (148)	8.6 (125)	5.5 (80)	15.8 (229)	7.9 (115)
		CL 300	-29°C (-20°F)	40 (580)	40 (580)	40 (580)	40 (580)	40 (580)	40 (580)	40 (580)	40 (580)	40 (580)	28.3 (410)	16 (232)	16 (232)
	L1	CL 150	-46°C (-50°F)	19.8 (287)	19.5 (283)	18.2 (264)	17.7 (257)	15.8 (229)	13.8 (200)	12.1 (175)	10.2 (148)	8.6 (125)	----	15.8 (229)	7.9 (115)
		CL 300	-46°C (-50°F)	40 (580)	40 (580)	40 (580)	40 (580)	40 (580)	40 (580)	40 (580)	40 (580)	40 (580)	----	16 (232)	16 (232)
	S1	CL 150	-60°C (-75°F)	19 (276)	18.4 (267)	17.2 (249)	16.2 (235)	14.8 (215)	13.7 (199)	12.1 (175)	10.2 (148)	8.6 (125)	5.5 (80)	15.2 (220)	7.6 (110)
		CL 300	-60°C (-75°F)	25 (363)	25 (363)	25 (363)	25 (363)	25 (363)	25 (363)	25 (363)	25 (363)	25 (363)	25 (363)	16 (232)	10 (145)
	S2	CL 150	-196°C (-320°F)	19 (276)	18.4 (267)	17.2 (249)	----	----	----	----	----	----	----	15.2 (220)	----
		CL 300	-196°C (-320°F)	25.0 (363)	25.0 (363)	25.0 (363)	----	----	----	----	----	----	----	16.0 (232)	----

NOTE

- Outlet pressure for temperatures above 50°C (120°F) should not exceed the EN 1092-1 flange rating.
- Maximum backpressure on the balanced bellows version must also be limited to 40% of the set pressure of the valve.
- Outlet pressure for temperatures above 38°C (100°F) should not exceed the ANSI B16.5 flange rating.

MINIMUM SET PRESSURES

EMC and EMH: 0.2 barg (3 psig)

EMB: 2.0 barg (29 psig)

CROSBY EM-SERIES

SPRING LOADED PRESSURE SAFETY VALVES

DIMENSIONS AND WEIGHTS

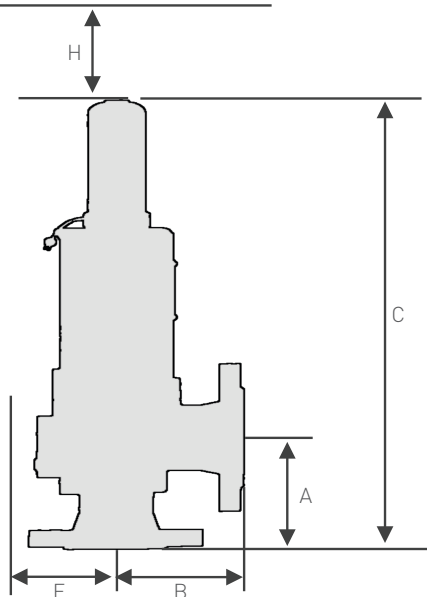

Inlet x Outlet	DN	25 x 40	32 x 50	40 x 65	50 x 80	65 x 100	80 x 125		100 x 150		
		Standard					Standard	High Pressure	Standard	High Pressure	
A	All Dimensions	105	115	140	150	170	195	195	220	220	
B	in mm	100	110	115	120	140	160	160	180	180	
EMC and EMH Configurations											
C (Total Height), mm	Cap J	410	453	569	615	729	836	937	922	1029	
	Cap K	422	465	581	627	741	848	949	934	1041	
	Cap C	411	454	570	615	730	837	938	923	1030	
	Cap D	410	453	570	615	729	836	938	922	1029	
	Cap E	423	465	582	627	742	848	950	934	1041	
	EMB Configurations										
E ² , mm	Cap J	441	487	601	665	785	873	974	947	1054	
	Cap K	453	499	613	677	797	885	986	959	1066	
	Cap C	442	488	605	665	786	874	975	948	1055	
	Cap D	441	487	605	665	785	873	974	947	1054	
	Cap E	453	499	613	677	797	885	986	959	1066	
H, mm	Cap J or K	58	70	75	83	93	108	108	123	123	
	Cap C or E	88	88	130	130	193	193	193	219	219	
Weight, kg	Cap D or E	118	118	118	118	210	210	210	210	210	
	All	120	120	155	155	180	180	180	195	195	
	EMC and EMH Configurations										
	Cap J or K	8.5	15	22	31	45	64	84	84	103	
	Cap C	9.5	16	24	33	48	67	87	89	108	
	Cap D or E	10	16.5	24	33	48	67	87	89	108	
	EMB Configurations										
Cap J or K	10	16	23	34	48	70	87	87	105		
Cap C	11	17	25	37	51	73	90	92	110		
Cap D or E	11.5	17.5	25	37	51	73	90	92	110		

NOTES

1. Low/High Set Pressure Ranges are as follows:

Inlet Size	Low Pressure	High Pressure	Low Pressure	High Pressure
	in bar		in psi	
EMC, DN 80 (3 in.)	< 16.5	>= 16.5	< 240	>= 240
EMH, DN 100 (4 in.)	< 9	>= 9	< 130	>= 130
EMB, DN 80 (3 in.)	< 15.5	>= 15.5	< 225	>= 225
	< 9	>= 9	< 130	>= 130

2. The 'E' dimension is the minimum required to operate the lifting lever.

CROSBY EM-SERIES

SPRING LOADED PRESSURE SAFETY VALVES

DIMENSIONS AND WEIGHTS

Inlet x Outlet	NPS	1 x 1 1/2	1 1/4 x 2	1 1/2 x 2 1/2	2 x 3	2 1/2 x 4	3 x 5		4 x 6		
				Standard			Standard	High Pressure	Standard	High Pressure	
A	All Dimensions	4 1/8	4 1/2	5 1/2	5 7/8	6 3/4	7 5/8	7 5/8	8 5/8	8 5/8	
B	in inches	3 7/8	4 3/8	4 1/2	4 3/4	5 1/2	6 1/4	6 1/4	7 1/8	7 1/8	
EMC and EMH Configurations											
C (Total Height)	Cap J	16 1/4	17 3/4	22 1/2	24 1/4	28 3/4	33	37	36 1/4	40 1/2	
	Cap K	16 1/2	18 1/4	22 3/4	24 3/4	29 1/4	33 1/2	37 1/4	36 3/4	41	
	Cap C	16 1/4	17 3/4	22 1/2	24 1/4	28 3/4	33	37	36 1/4	40 1/2	
	Cap D	16 1/4	17 3/4	22 1/2	24 1/4	28 3/4	33	37	36 1/4	40 1/2	
	Cap E	16 3/4	18 1/4	23	24 3/4	29 1/4	33 1/2	37 1/2	36 3/4	41	
	EMB Configurations										
	Cap J	17 1/4	19 1/4	23 3/4	26 1/4	31	34 1/4	38 1/4	37 1/4	41 1/2	
	Cap K	17 3/4	19 3/4	24 1/4	26 3/4	31 1/2	34 3/4	38 3/4	37 3/4	42	
	Cap C	17 1/2	19 1/4	23 3/4	26 1/4	31	34 1/2	38 1/2	37 1/4	41 1/2	
	Cap D	17 1/4	19 1/4	23 3/4	26 1/4	31	34 1/4	38 1/4	37 1/4	41 1/2	
Cap E	17 3/4	19 3/4	24 1/4	26 3/4	31 1/2	34 3/4	38 3/4	37 3/4	42		
E ^[2] , in.	Cap J or K	2 1/4	2 3/4	3	3 1/4	3 3/4	4 1/4	4 1/4	4 3/4	4 3/4	
	Cap C	3 1/2	3 1/2	5 1/8	5 1/8	7 3/8	7 3/8	7 3/8	8 5/8	8 5/8	
	Cap D or E	4 7/8	4 7/8	4 7/8	4 7/8	8 1/4	8 1/4	8 1/4	8 1/4	8 1/4	
H, in.	All	4 3/4	4 3/4	6	6	7	7	7	7 3/4	7 3/4	
EMC and EMH Configurations											
Weight, lbs	Cap J or K	19	33	49	68	99	141	185	185	227	
	Cap C	21	35	53	73	106	148	192	196	238	
	Cap D or E	22	36	53	73	106	148	192	196	238	
	EMB Configurations										
	Cap J or K	22	35	51	75	106	154	192	192	232	
	Cap C	24	37	55	82	112	161	198	203	243	
Cap D or E	25	39	55	82	112	161	198	203	243		

NOTES

1. Low/High Set Pressure Ranges are as follows:

Inlet Size	Low Pressure	High Pressure	Low Pressure	High Pressure
	in bar		in psi	
EMC, DN 80 (3 in.)	< 16.5	>= 16.5	< 240	>= 240
EMH, DN 100 (4 in.)	< 9	>= 9	< 130	>= 130
EMB, DN 80 (3 in.)	< 15.5	>= 15.5	< 225	>= 225
	DN 100 (4 in.)	< 9	>= 9	< 130

2. The 'E' dimension is the minimum required to operate the lifting lever.

CROSBY EM-SERIES

SPRING LOADED PRESSURE SAFETY VALVES

EM SERIES SELECTION GUIDE

Example: EM C 050 - 3A 41 L1 C B J P - RLDG

Valve Type

EM Series EM

Design

C Conventional
B Bellows (steel)
H Open bonnet

Connection Size

	EN 1092-1 Flanges		ANSI B16.5 Flanges
025	DN 25 x 40	A01	1 x 1½ in.
032	DN 32 x 50	A14	1½ x 2 in.
040	DN 40 x 65	A15	1½ x 2½ in.
050	DN 50 x 80	A02	2 x 3 in.
065	DN 65 x 100	A25	2½ x 4 in.
080	DN 80 x 125	A03	3 x 5 in.
100	DN 100 x 150	A04	4 x 6 in.

Bonnet Design

- Standard
H High Pressure, DN 80 to 100 (3 in. to 4 in.) only

Flanges Class, Inlet x Outlet

Per EN 1092-1

1A	PN 10 x PN 10	4A	PN 40 x PN 10
2A	PN 16 x PN 10	4B	PN 40 x PN 16
2B	PN 16 x PN 16		Per ANSI B16.5
3A	PN 25 x PN 10	A1	CL 150 x CL 150
3B	PN 25 x PN 16	A3	CL 300 x CL 150

Flange Facing, Inlet x Outlet (2 digits)

1	Form B1	5	Form F	R	RF
2	Form B2	8	Form C		
4	Form E	9	Form D		

Material Variation

C1 Carbon steel
L1 Low temperature carbon steel
S1 Stainless steel > -60°C (-75°F)
S2 Stainless steel, cryogenic applications

Spring Material

C Chrome Vanadium **S** Stainless steel 316
T Tungsten steel **N** Inconel® X750

Seat Material

0 Metal **6** Stellite nozzle only
5 Stellite disc and nozzle **7** Stellite disc only

Cap and Lift Levers

J Threaded cap **D** Packed lever
C Open lever **E** Packed lever with test gag
K Threaded with test gag

Code and Certifications

P PED and EN4126-1 **N** No code
E EN4126-1 only, no code

Model Number Supplements Separator

Model Number Supplements, in any order

DM	Body drain, metric	BM	Bonnet vent, metric	Rx	Restricted lift: x= 3, 4 ...8 for 30%, 40%... 80% of full lift
DN	Body drain, NPT	BN	Bonnet vent, NPT	V7	Monitoring with Rosemount 708 acoustic transmitter
B3	Bellows 316L	BS	Bonnet with bug screen		
B6	Bellows Inc 625 LCF	NL	Government ring		

EMC050-3A41L1C0JP-R6 =

Conventional EM series safety valve, DN 50 PN 25 Form E inlet x DN 80 PN 10 Form B1 outlet, low temperature carbon steel construction with CrV spring, metal seat, plain threaded cap, certified per PED and EN4126-1 standard, lift restricted for 60% of full lift.

CROSBY EM-SERIES

SPRING LOADED PRESSURE SAFETY VALVES

SPARE PARTS

Description	Key	Material	Valve Style	Part Variation	Inlet Size						
					DN 25 (1 in.)	DN 32 (1¼ in.)	DN 40 (1½ in.)	DN 50 (2 in.)	DN 65 (2½ in.)	DN 80 (3 in.)	DN 100 (4 in.)
Gasket Kit ⁽¹⁾	40, 41, 82 and 17	Graphite Fiber	All styles	All variations ⁽⁴⁾	11537336	11537337	11537338	11537339	11537341	11537342	11537343
Disc ⁽²⁾	5	316L / 1.4404	EMC, EMH	Metal seat	11525728	11525729	11525730	11525731	11525732	11525733	11525734
		316L + Stellite Gr.6	EMC, EMH	Hardened Seat	11529470	11529471	11529472	11529473	11529474	11529475	11529476
Disc Deflector	6	316L	All styles	All variations	11525721	11525722	11525723	11525724	11525725	11525726	11525727
Disc Circlip	7	302	All styles	All variations	11525735	11525736	11525737	11525738	11525739	11525740	11525741
Ball ⁽⁴⁾	17	440C	All styles	C1, L1 and S1	11522340	11522340	11522341	11522342	11522343	11522344	11522345
		316L	EMC	S2 Materials	11537330	11537330	11537331	11537332	11537333	11537334	11537335
Bellows Assembly (bellows welded with disc)	55	316L / 1.4404	EMB	Metal seat	11525749	11525750	11525751	11525752	11525753	11525754	11525755
		316L / Inc. 625 LCF	EMB	Metal seat	11525756	11525757	11525758	11525759	11525760	11525761	11525762
		316L / 1.4404 + Stellite Gr. 6	EMB	Hardened seat	11546712	11546713	11546714	11546715	11546716	11546717	11546718
		316L / Inc. 625 LCF + Stellite Gr. 6	EMB	Hardened seat	11546719	11546720	11546721	11546722	11546723	11546724	11546725
Spindle	15	431 / 1.4057	EMC, EMH	C1, L1 and S1	11522239	11522221	11522179	11522201	11522257	N/A	N/A
		431 / 1.4057	EMC, EMH	C1, L1 and S1 LP ⁽³⁾	N/A	N/A	N/A	N/A	N/A	11522287	11522316
		431 / 1.4057	EMC, EMH	C1, L1 and S1 HP ⁽³⁾	N/A	N/A	N/A	N/A	N/A	11522289	11522318
		431 / 1.4057	EMB	C1, L1 and S1	11522240	11522222	11522180	11522202	11522258	N/A	N/A
		431 / 1.4057	EMB	C1, L1 and S1 LP ⁽³⁾	N/A	N/A	N/A	N/A	N/A	11522288	11522317
		431 / 1.4057	EMB	C1, L1 and S1 HP ⁽³⁾	N/A	N/A	N/A	N/A	N/A	11522290	11522319
		316L / 1.4404	EMC	S2 Materials	11525793	11525792	11525790	11525791	11525794	N/A	N/A
		316L / 1.4404	EMC	S2 LP ⁽³⁾	N/A	N/A	N/A	N/A	N/A	11525796	11525798
Split Collar	16	17-4 PH	All styles	C1, L1 and S1	11522225	11522225	11522183	11522205	11522262	11522293	11522322
		Inconel® 625	All styles	S2 Materials	11537325	11537325	11537323	11537324	11537326	11537328	11537329
Guide	10	416 / 1.4005	All styles	C1, L1 and S1	11522238	11522220	11522178	11522200	11522256	11522286	11522315
		316L / 1.4404	EMC	S2 Materials	11537319	11537318	11537314	11537317	11537320	11537321	11537322
Adjusting Bolt Bush	31	PTFE	All styles	All variations	11522224	11522224	11522182	11522204	11522261	11522292	11522321

NOTES

- Includes the following: cap gasket (40), 3 guide gaskets (41), standard ball (17) and gag plug gasket (82).
- The disc of the EMB style is welded to the bellows. See below for complete spare assembly bellows+disc
- Low/High Pressures Set Pressure ranges are as follows:

Inlet Size	Low Pressure	High Pressure	Low Pressure	High Pressure
	in bar		in psi	
EMC, DN 80 (3 in.)	< 16.5	>= 16.5	< 240	>= 240
EMH, DN 100 (4 in.)	< 9	>= 9	< 130	>= 130
EMB, DN 80 (3 in.)	< 15.5	>= 15.5	< 225	>= 225
	DN 100 (4 in.)	< 9	>= 9	< 130

- Standard ball in 440C is included in the Gasket Kit. Ball for cryogenic variation S2 is not included.

CROSBY EM-SERIES

SPRING LOADED PRESSURE SAFETY VALVES

PRESSURE RELIEF DEVICE SIZING AND SELECTION SOFTWARE

Emerson PRV²SIZE incorporates over 135 years of experience and engineering expertise for an extensive array of Anderson Greenwood, Crosby and Varec pressure relief devices and related products in one software package. It enables you to address numerous applications in a single sizing and selection platform without the need to use two or more sizing programs.



Emerson PRV²SIZE features:

- User-friendly interface
 - Sizing calculations can be saved at any point
 - Multiple tags can be opened at one time
- Ability to sort data using a variety of parameters
- Fully configured product selection
- Industry standard sizing methodologies
- Drop-down boxes allow instantaneous change of sizing methodology from API to ASME and vice-versa
- 2:1 elliptical head tanks for fire sizing applications
- Catalog integration from existing product literature PDF's
- Detailed product specifications including cross sectional drawings with dimensions and weights
 - U.S. customary system and metric units
- Advanced tools to export and import device tag numbers with the ability to mail files directly from the software program
- Flow curves for pressure relief valves
- Individual capsule summaries of each product including an image of the selected product

Emerson PRV²SIZE website: valvesizing.emerson.com

VCTDS-16900-EN © 2025 Emerson Electric Co. All rights reserved 08/25. Crosby is a mark owned by a subsidiary of Emerson Electric Co. The Emerson logo is a trademark and service mark of Emerson Electric Co. All other marks are property of their respective owners.

Neither Emerson nor any of its affiliated entities assume responsibility for the selection, use or maintenance of any product. Responsibility for proper selection, use, and maintenance of any product remains solely with the purchaser and end user.

The contents of this publication are presented for informational purposes only, and while every effort has been made to ensure their accuracy, they are not to be construed as warranties or guarantees, express or implied, regarding the products or services described herein or their use or applicability. All sales are governed by our terms and conditions, which are available upon request. We reserve the right to modify or improve the designs or specifications of such products at any time without notice.

Emerson.com