



KEYSTONE F89 PNEUMATIC ACTUATOR

SIL SAFETY MANUAL

SIL safety manual for F89 Rack and Pinion Pneumatic Actuators



1 FUNCTIONAL SPECIFICATION

The safety function for Keystone F89 R&P - Series pneumatic actuator is defined as follows:

Double-Acting scenario:

- a. When an unsafe condition is detected in a plant by a process sensor, the controller, via actuator control system, drives the actuator to **close** the shut-down valve, depressurizing (if under pressure) the opening side of the actuator and pressurizing the closing side of the actuator.
- b. When an unsafe condition is detected in a plant by a process sensor, the controller, via actuator control system drives the actuator to **open** the blow-down valve, depressurizing (if under pressure) the closing side of the pneumatic actuator and pressurizing the opening side of the pneumatic actuator.

Single-Acting scenario:

- a. When an unsafe condition is detected in a plant by a process sensor, the controller, via actuator control system drives the actuator to rotate with sufficient torque to move a valve to its fail-safe state when hold-position air pressure is released.

2 CONFIGURATION OF THE PRODUCT

The Keystone F89 R&P - Series are pneumatically-operated actuators designed to operate butterfly, ball valves and any quarter-turn mechanism. It is suitable for a range of applications in industries such as processing, chemical, food and beverage, mining, power and water, and available globally. Both the double-acting and single-acting (spring-return) versions of the Keystone F89 R&P - Series pneumatic actuators are designed in such a way that there are no moving parts on the outside (except for the position indicator). This makes them safe, easy to install and virtually maintenance free.

For further details about actuator configurations, please refer to the Keystone F89 R&P - Series Product Data Sheets, safety guide and Installation, Operation and Maintenance Manual

CONTENTS

1	Functional specification	1
2	Configuration of the product	1
3	Service condition limitations (limitation of use)	2
4	Expected lifetime	2
5	Failure modes and estimated failure rates	3
6	Installation and site acceptance procedure	4
7	Periodic test and maintenance requirements	4
7.1	General	4
7.2	Full-stroke test	4
7.3	Partial-stroke test	4
7.4	Proof test and periodic maintenance	4
8	Hardware fault tolerance	5
9	Classification	5
10	Safe failure fraction	5
11	Mean repair time	5
12	Systematic capability	5

The Keystone Brand Actuator Selection Procedure provides functional definition with specifics on input variables and performance. In any case, the choice of the safety function to be implemented is responsibility of the system integrator.

KEYSTONE F89 PNEUMATIC ACTUATOR

SIL SAFETY MANUAL

3 SERVICE CONDITION LIMITATIONS (LIMITATION OF USE)

The operating capabilities are listed below:

- **Operating medium:** Compressed air (dry and lubricated)
- **Maximum Operating Pressure:**
 - Pneumatic service.
 - 8.3 bar (120 psi) max. dynamic
 - 10 bar (140 psi) max. static
- **Temperature range:** Temperature extremes require different solutions to maintain actuator operational integrity and reliability. For each Keystone F89 - Series actuator is available in three different temperature executions.
 - Standard temperature version:
-20 °C to 80 °C [-4 °F to 176 °F]
 - Low temperature version:
-52 °C to 65 °C [-62 °F to 149 °F]
 - High temperature version:
-15 °C to 150 °C [-5 °F to 302 °F]
- **Torque output range:**
 - Double-acting F89 R&P - Series actuators, requiring pressure to rotate in either direction, are available with a torque range between 11 Nm (97 lbf.in) and 4173 Nm (36,955 lbf.in)
 - Spring-return F89 - Series actuators, require pressure in only one direction of travel and are suitable for air-fail close and air-fail to open applications without modification. These models are available with a spring end torque between 6 Nm (51 lbf.in) and 1663 Nm (14,729 lbf.in)
- **Travel adjustment:**
 - Optimized product flow with standard mounted travel stops for valve position adjustment in open and close position (+/- 5° at each end of travel)
 - 0-100% travel stop available on request
- **Safety function:**
 - Pre-compressed spring cartridge design for ease of assembly and disassembly
 - Anti-blowout drive pinion
 - No stopper bolt extends beyond the body
 - Integrated connections
 - Fail-safe actuator, spring-close and spring-open
 - Adjustable stopper (+/- 5°)

Use the 4 (B)-Port for safety related systems on Double-acting actuators:

Assembly Code: CW

= Safety function is counterclockwise rotation

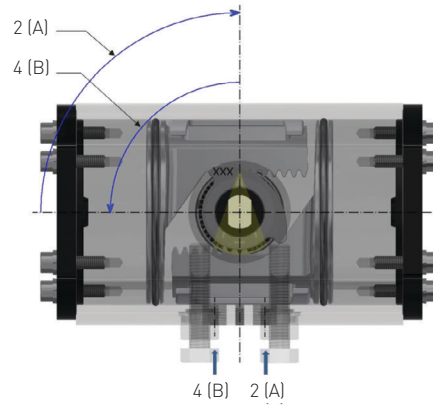

Assembly Code: CC

= Safety function is clockwise rotation

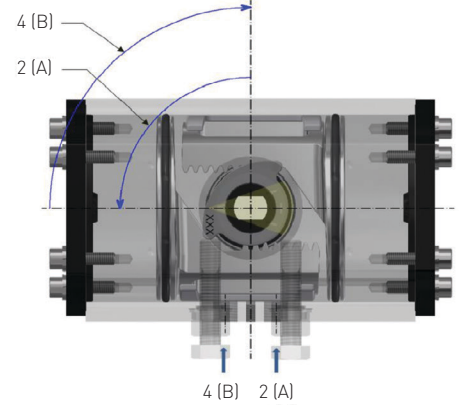

4 EXPECTED LIFETIME

Actuator lifetime (for which failure rates indicated in section 5 are ensured) strongly depends on operating conditions.

For normal service conditions, Keystone F89 R&P - Series actuators can be in good conditions with max 500,000 cycles or 15 years with regular inspection whichever comes first. Normal working life is the number of cycles as defined in Table 1 of EN 15714-3.

Keystone F89 R&P Series carry a warranty period of:

- 12 months after installation or 18 months after delivery, whichever is earlier.

KEYSTONE F89 PNEUMATIC ACTUATOR

SIL SAFETY MANUAL

5 FAILURE MODES AND ESTIMATED FAILURE RATES

Warranty data and details from the extensive testing that is performed in-house by the manufactures were used to perform the calculations. Failure data for 2016-17 were provided by the company and used in this study.

• **Determination of SIL parameters**

Based on the FMEDA study carried out for actuator series, the individual failure rates, SFF and DC were calculated. The results are given in below table covering the variants of Keystone actuator F89 R&P – Series:

TABLE 1 - DETERMINATION OF SIL PARAMETERS

Variants	Failure rate (number of failures/hrs.)				SFF	DC
	λ_{SD}	λ_{SU}	λ_{DD}	λ_{DU}	%	%
Spring return (SR)	7.16E-09	0.00E+00	1.79E-09	7.45E-10	92	71
Double Acting (DA)	7.31E-09	0.00E+00	1.91E-09	4.77E-10	95	80



• **Failure distribution**

An analysis of the failures was carried out for the individual components and is given in following table:

TABLE 2 - FAILURE DISTRIBUTION

Types of Keystone Actuator F89	Component	Failures (%)
Spring Return (SR)	End cap washer	12
	Bolt – end cap	12
	Piston	9
	End cap	9
	O-ring (piston)	9
	Spring Cartridge Assembly	6
Double Acting (DA)	End cap washer	13
	Bolt – end cap	13
	Piston	10
	End cap	10
	O-ring (piston)	10
	Body	7

The FMEDA analysis shows that components such as pinion and end cap contribute significantly to the dangerous undetected failure mode. The company may address the causes for such failures.

6 INSTALLATION AND SITE ACCEPTANCE PROCEDURE

Any necessary installation and site acceptance procedures are discussed in the Keystone F89 R&P - Series actuators Installation, Operation and Maintenance manual. The Installation, Operation and Maintenance manual defines exercising of the actuator after installation and defines testing after maintenance.

7 PERIODIC TEST AND MAINTENANCE REQUIREMENTS

Any necessary installation and site acceptance procedures are discussed in the Keystone F89 R&P - Series actuators Installation, Operation and Maintenance manual. The Installation, Operation and Maintenance manual defines exercising of the actuator after installation and defines testing after maintenance.

7.1 General

Please consider that the information in this paragraph are relevant only in regards of Reliability Tests; please refer to Document, Installation, Operation and Maintenance manual for detailed information about product maintenance, handling and storage.

Diagnostic tests may be made to increase the system reliability (Full-stroke or Partial-stroke test).

"On-site" tests depend on project/plant facilities/requirements; however, a functional test must be executed on site, prior actuator operation

7.2 Full-Stroke test

The "Full-Stroke Test" ("On-line") must be performed to satisfy the PFD_{AVG} (average probability of failure on demand) value. The full-test frequencies will be defined by the final integrator in relation to the defined SIL level to achieve.

• Procedure:

- Operate the actuator/valve assembly for No. 2 open/close complete cycles with complete closing of the valve.
- Verify the correct performing of open – close maneuver (for example, check locally, or automatically via logic solver, the correct movement of the actuator/valve).

Considering the application of the above described Full-Stroke Test Procedure, the "Test Coverage" can be considered 99%.

7.3 Partial-Stroke test

The "Partial-Stroke Test" ("On-line") can be performed to improve the PFD_{AVG} value.

A typical partial-stroke value is 15% of the stroke.

The "Partial-Stroke Test" ("On-line") can be performed to satisfy PFD_{AVG} (average probability of failure on demand) value.

- Recommended Test Interval = 1 to 3 months.

• Procedure:

- Operate the actuator/valve assembly for No. 1 open/close cycles 15/20% of the stroke.
- Verify the correct performing of partial-stroke operation (for example, check locally, or automatically via logic solver, or via the PST system the correct movement of the actuator/valve till 15/20% of the stroke).

The above parameters to check will depend from the partial-stroke test system available. Considering the application of the above described Partial-Stroke Test procedure, the "Diagnostic Coverage" is >90%.

7.4 Proof test and periodic maintenance

We advise to perform the following checks upon each proof test interval complying with the rules and regulations of the country of final installation:

- Visually check the entire actuator as well as the control system (where foreseen).
- Ensure there are no leaks on the actuator parts under pressure.
- Check pneumatic connections for leaks. Tighten tube fittings as required.
- Check if manual override (where foreseen) is regular.
- Check if pneumatic filter cartridge (where foreseen) is sound and filter bowl (where foreseen) has been cleaned properly.
- Check the setting of the relief valves (where foreseen).
- Verify that the power fluid supply pressure value is within the required range.
- Remove built-up dust and dirt from all actuator surfaces.
- Inspect actuator paint work for damages to ensure continued corrosion protection. Touch-up as required in accordance with the applicable paint specification.
- Operate the actuator/valve assembly for No. 2 open/close complete cycles with complete closing of the valve.
- Verify the correct performing of open – close operations (for example, check locally, or automatically via logic solver, the correct movement of the actuator).

The Installation, Operation and Maintenance manual defines under normal operating conditions and when basic pneumatic system maintenance procedures are applied, the F89 actuator will require minimum maintenance for hundred thousand of cycle. If O-ring wear out and air leakage occurs, a soft goods kit can be ordered. This addresses components that may have age-related degradation. When the maintenance interval has elapsed, a complete overhaul of the actuator is required.

KEYSTONE F89 PNEUMATIC ACTUATOR

SIL SAFETY MANUAL

8 HARDWARE FAULT TOLERANCE

The hardware fault tolerance of the device is 0.

The requirements of minimum hardware fault tolerance (HFT) according to Tab.6 of IEC 61511-1 have to be observed but, as long as an assessment report has been performed fully in compliance with IEC 61508 part 1 to 7, alternative fault tolerance requirements have to be considered applicable according to Table 2 of IEC 61508-2 as per par. 11.4.5 of IEC 61511-1.

9 CLASSIFICATION

The equipment is classified Type A according to IEC 61508-2.

10 SAFE FAILURE FRACTION

SFF = 0 without external diagnostic tests.

SFF > 0 with external diagnostic tests, carried out according to definition 3.8.7 of IEC 61508-4.

- SFF = 91% with Partial-Stroke Test.
- SFF = 99% with Full-Stroke Test.

The SFF shall be evaluated for the entire final element sub-system.

The diagnostic test shall be performed considerably more often than the demand of the safety function.

11 MEAN REPAIR TIME

Mean Repair Time (MRT) of the actuator is assumed to be 24 hours.

NOTICE

The MRT is estimated considering availability of skilled personnel for maintenance, spare parts and adequate tools and materials on site (that is, it encompasses the effective time to repair and the time before the component is put back into operation).

Procedures to repair or replace the Keystone F89 R&P - Series actuators are provided in the respective Installation, Operation and Maintenance manual. Please refer to the Installation, Operation and Maintenance manual for any tools required for repair and replacement and required competency of technicians. Maintenance and subsequent test procedures are also covered in the Installation, Operation and Maintenance manual. Any failures, identified by the end-user during maintenance, repair or proof testing, that potentially impact the functional safety of the Keystone F89 R&P - Series actuators should be reported back to Emerson Customer Service Coordinator.

12 SYSTEMATIC CAPABILITY

The systematic capability of the device is 3.

This systematic capability is guaranteed only if the user:

- Use the device according to the instructions for use and to the present manual.
- Use the device in the appropriate environment (limitation of use).

VCOSI-16511-EN © 2021 Emerson Electric Co. All rights reserved 07/21. Keystone is a mark owned by one of the companies in the Emerson Automation Solutions business unit of Emerson Electric Co. The Emerson logo is a trademark and service mark of Emerson Electric Co. All other marks are the property of their prospective owners.

The contents of this publication are presented for informational purposes only, and while every effort has been made to ensure their accuracy, they are not to be construed as warranties or guarantees, express or implied, regarding the products or services described herein or their use or applicability. All sales are governed by our terms and conditions, which are available upon request. We reserve the right to modify or improve the designs or specifications of such products at any time without notice.

Emerson Electric Co. does not assume responsibility for the selection, use or maintenance of any product. Responsibility for proper selection, use and maintenance of any Emerson Electric Co. product remains solely with the purchaser.

Emerson.com/FinalControl